



# Motorized Electromechanical Swing Gate

## WMD-06

ASSEMBLY AND OPERATION MANUAL



CE EAC



**Motorized  
Electromechanical  
Swing Gate**

***WMD-06***

**Assembly and Operation Manual**

# CONTENTS

1 APPLICATION.....	3
2 OPERATION CONDITIONS.....	3
3 TECHNICAL SPECIFICATIONS.....	4
4 DELIVERY SET.....	5
4.1 Standard delivery set.....	5
4.2 Additional equipment supplied on request.....	5
5 PRODUCT DESCRIPTION.....	6
5.1 Main features.....	6
5.2 Design.....	6
5.3 RC panel.....	9
5.4 Parameters of input and output signals.....	11
5.5 Operation contingences during gate operation.....	14
6 MARKING AND PACKAGING.....	15
7 SAFETY REQUIREMENTS.....	16
7.1 Installation safety.....	16
7.2 Operation safety.....	16
8 ASSEMBLY AND INSTALLATION.....	17
8.1 General recommendations.....	17
8.2 Tools and equipment required for installation.....	17
8.3 Appropriate length of cables.....	17
8.4 Installation sequence.....	18
9 OPERATION.....	22
9.1 Power-up.....	22
9.2 Pulse control mode.....	22
9.3 Potential control mode.....	23
9.4 Emergency situations.....	24
9.5 Troubleshooting.....	24
10 MAINTENANCE.....	25
11 TRANSPORTATION AND STORAGE.....	25
APPENDIX A. Control signal algorithm in pulse control mode.....	26
APPENDIX B. Control signal algorithm in potential control mode.....	27

***Dear customer!***

*Thank you for purchasing the PERCo product.*

*Please follow instructions given in this Manual carefully, and this quality product will provide many years of trouble-free use.*

The Assembly and Operation Manual (hereinafter – the Manual) contains the instructions you will need for safe transportation, storage, installation, operation and maintenance of the **WMD-06** electromechanical motorized swing gate.

The product installation must be carried out by qualified installers in strict accordance with the Manual.

Abbreviations adopted in the Manual:

- ACS – access control system;
- RC – remote control;
- WRC – wireless remote control.

## **1 APPLICATION**

The **WMD-06** electromechanical motorized fail-safe swing gate (hereinafter – the swing gate) is designed for managing pedestrian flows at entrance points of industrial facilities, banks, administrative buildings, retail outlets, railway terminals, airports, etc. Being an up-market model, it is recommended for fitting the highest requirements for design and comfort. It can be installed together with other turnstiles and barriers produced by **PERCo** or it can be used as a separate device.

It is recommended to define the number of swing gates necessary to secure fast and convenient passage in accordance with throughput rate (see Section 3). For example it is recommended to install one swing gate per every 500 entrants or in accordance with peak throughput rate not exceeding 12 persons per minute.

## **2 OPERATION CONDITIONS**

The swing gate with regard to resistance to environmental exposure complies with GOST 15150-69, category U4 (operation in premises with climate control).

Operation of the swing gate is allowed at ambient air temperature from +1°C to +45°C and at relative air humidity of up to 70% at +27°C.

### 3 TECHNICAL SPECIFICATIONS

DC operating voltage .....	24 V $\pm$ 10%
Current .....	max. 4.4 A
Power consumption .....	max. 105 W
Throughput rate in single passage mode.....	12 persons/min
Passage modes .....	3
Passageway width:	
with <b>AGG-650</b> swing panel.....	700 mm
with <b>AGG-900</b> swing panel.....	950 mm
Length of RC cable <sup>1</sup> .....	min 6.6 m
Ingress protection rating .....	IP41 (EN 60529)
Electric shock protection class .....	III (IEC 61140)
Mean time to failure .....	min. 500 000 number of passages
Mean lifetime .....	min. 8 years
Overall dimensions (L $\times$ W $\times$ H):	
with <b>AGG-650</b> swing panel.....	795 $\times$ 147 $\times$ 1007 mm
with <b>AGG-900</b> swing panel.....	1045 $\times$ 147 $\times$ 1007 mm
Net weight:	
with <b>AGG-650</b> swing panel.....	max. 37 kg
with <b>AGG-900</b> swing panel.....	max. 41 kg

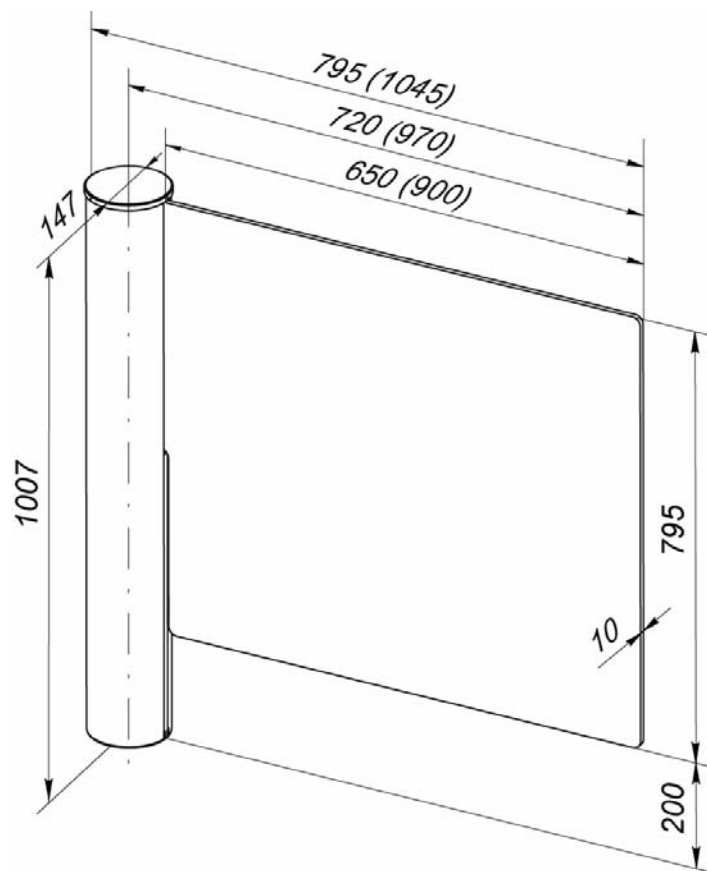

**Figure 1. Overall dimensions**

<sup>1</sup> Maximum length of RC cable is 30 m (supplied on request).

## 4 DELIVERY SET

### 4.1 Standard delivery set

**Basic equipment:**

Gate post .....	1
Glass panel .....	1



**Note:**

Type of panel (**AGG-650** or **AGG-900**) is chosen by the customer.

RC panel with cable .....	1
Hex-nut wrench S1.5 .....	1

**Gate installation kit:**

<i>PFG IH 10</i> («SORMAT», Finland) anchor bolt with washer and nut M10 .....	3
--------------------------------------------------------------------------------	---

**Panel installation kit:**

Bolt M10×35 A2.....	4
Nut M10 A2 .....	4
Plain washer.....	4
Spring washer .....	4
Expanded washer .....	4
Plastic washer .....	4
Plastic bushing.....	4

**Operational documentation:**

Certificate .....	1
Assembly and Operation manual .....	1
Template for gate installation .....	1

**Package:**

Box 1 (gate post and remote control panel) .....	1
Box 2 (swing panel) .....	1

### 4.2 Additional equipment supplied on request

In addition to the standard delivery set the following equipment can be supplied on request:

Power supply unit .....	1
WRC kit <sup>1</sup> .....	1

<sup>1</sup> WRC kit consists of a receiver connected to the control board of the gate and two transmitters (tags) with operation range up to 40 m.

## 5 PRODUCT DESCRIPTION

### 5.1 Main features

- The swing gate can be operated autonomously from the RC panel or WRC as well as from an access control system (ACS). There are two variants of the gate control – pulse control mode and potential control mode.
- The swing gate can be supplied with two types of swing panel: 650 mm or 900 mm. Overall dimensions of the gate are shown in Fig. 1.
- External components of the swing gate (except for swing panel) are made of brushed stainless steel. The swing panel is made of 10 mm thick tempered glass.
- The swing gate is a normally open unit i.e. in case of power failure the swing panel can be rotated through an angle of  $\pm 90^\circ$ .
- Safe operating voltage – max. 28 V.
- Low power consumption – max. 105 W.

### 5.2 Design

Design of the swing gate is shown in Fig. 2. The numbers of the items in brackets are given according to Fig. 2, unless stated otherwise.

The gate consists of the stationary base (1), rotary support (7) that holds glass panel (4), housing (2) and cover (3). Metal ring (5) and plastic ring (12) provide support of housing (2) and its rotation around stationary base (1). Decorative plate (15) is fixed with a screw (16).

The gate post is installed on anchors' studs (9) and fixed with nuts (10) and washers (11)

The gate post contains units providing its operation: rotary electric drive with rotation sensor, electromagnetic stopper unit, bearing units, drive control board (6).

RC panel is included into delivery set (17).

The gate is operated with +24 V DC voltages via cable (13).

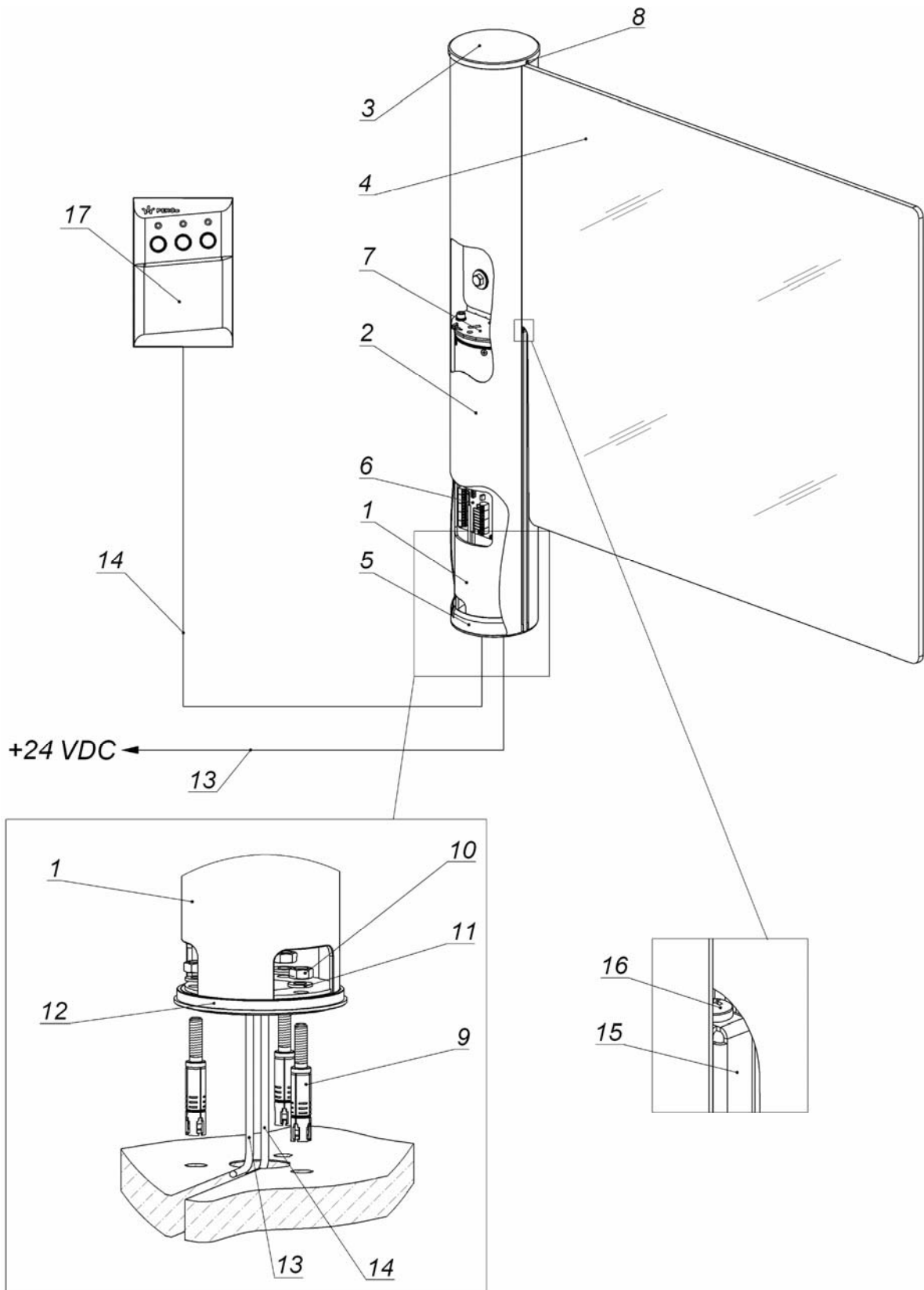

**Figure 2. Overall view of the gate**

- 1 – stationary base; 2 – housing; 3 – cover; 4 – glass panel; 5 – metal ring;
- 6 – control board; 7 – rotary support; 8 – screw M3 (3 units); 9 – anchor; 10 – nut M10;
- 11 – washer; 12 – plastic ring; 13 – power cable;
- 14 – control cable (from RC panel / WRC device / ACS controller );
- 15 – decorative plate; 16 – screw M4; 17 – RC panel



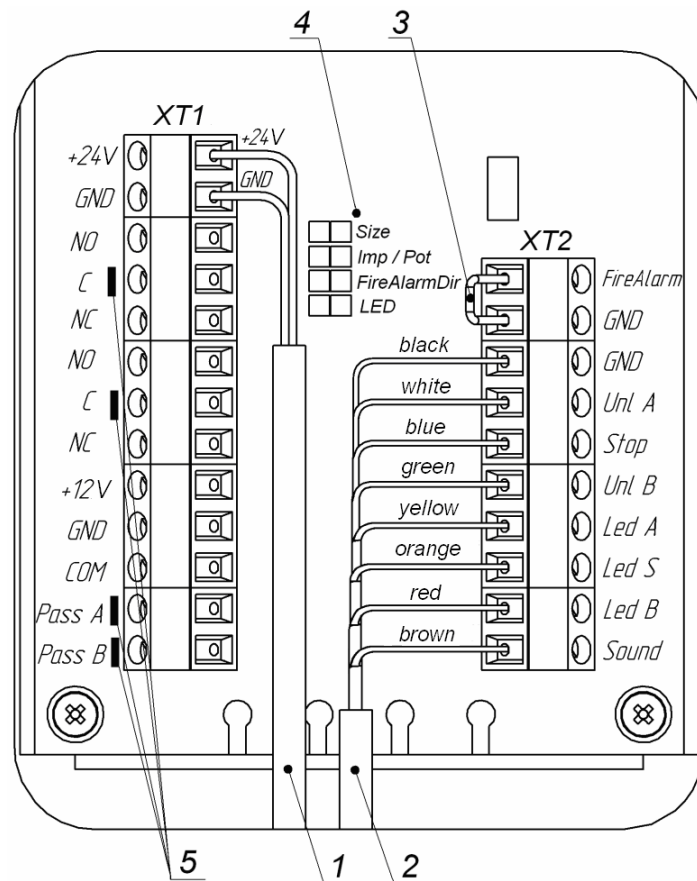

**Figure 3. External view of the control board**

- XT1, XT2** – connector blocks; 1 – power cable +24 V;
- 2 – control cable (from RC panel / WRC unit / ACS controller);
- 3 – cable jumper (installed on default);
- 4 – connectors (all jumpers are installed on default); 5 – LED indicators.

The control board is installed in the gate post. The external view of the board is shown in Fig. 3. The board contains:

- **XT1** and **XT2** – connector blocks are designed for power supply, input-output of control signals and indication. Marking and description of **XT1** and **XT2** connector's contacts of the control board are given in Table 1.
- **Size** – connector is designed for selection of swing panel type installed on the gate. If the **AGG-900** panel is used, the jumper shall be removed, if the **AGG-650** panel is used – the jumper shall be installed. The jumper is removed on default.
- **Imp / Pot** – connector is designed for selection of control mode of the gate. If the jumper is installed, the gate operates in the pulse mode, if the jumper is not installed, the gate operates in the potential mode. The jumper is installed on default.
- **FireAlarmDir** – connector is designed for selection of opening direction of the gate when the *Fire Alarm* emergency unblocking signal is applied. If the jumper is installed, the swing panel opens in direction A (see Figure 5), if the jumper is not installed, the swing panel opens in direction B. The jumper is installed on default.
- **LED** – connector is designed for turn-off of LED indicators located on the control board. If the jumper is installed, indication is on. If the jumper is not installed, indication is off. The jumper is installed on default.

**Table 1. Contacts of the control board**

Connector block	№	Item	Function of the contact
<b>XT1</b>	1	+24 V	Connection of external power supply
	2	GND	
	3	NO	Light A relay contacts – connection of remote indicator for direction A
	4	C	
	5	NC	
	6	NO	Light B relay contacts – connection of remote indicator for direction B
	7	C	
	8	NC	
	9	+12 V	“+” of the power supply of RC device
	10	GND	Negative terminal of the power source
	11	Common	Common contact for <i>PASS A</i> , <i>PASS B</i> signals
	12	Pass A	<i>PASS A</i> relay contact (passage in direction A)
	13	Pass B	<i>PASS B</i> relay contact (passage in direction B)
<b>XT2</b>	1	Fire Alarm	Input for emergency unblocking device
	2	GND	
	3	GND	Negative terminal of the power source
	4	Unlock A	Inputs for gate control
	5	Stop	
	6	Unlock B	
	7	Led A	Indication outputs of RC panel
	8	Stop	
	9	Led B	
	10	Sound	Sound signal output of RC panel

### 5.3 RC panel

The RC panel (17) is a small table device made of shockproof ABS plastic that serves for manual setting of the operating modes and indication thereof. RC panel is connected to the control board (6) with flexible multicore cable (14), included into delivery set. The general view of the RC panel is shown in Figure 4.

The RC panel houses three control buttons to set passage modes of the swing gate. Above the buttons LED indicators are located. The **STOP** button in the middle serves for setting the “**Always locked**” operating mode, the **RIGHT** and **LEFT** buttons – for allowing passage in the chosen direction. The RC panel features a built-in piezoelectric buzzer for audio signals generation.

The standard orientation of the RC panel in relation to gate opening direction is shown in Figure 5. The orientation of the RC panel can be changed if necessary, in such case the connection of RC panel shown in Fig. 11 shall be changed by connecting of cable of the RC panel to **XT2** connector block in accordance with Table 2.

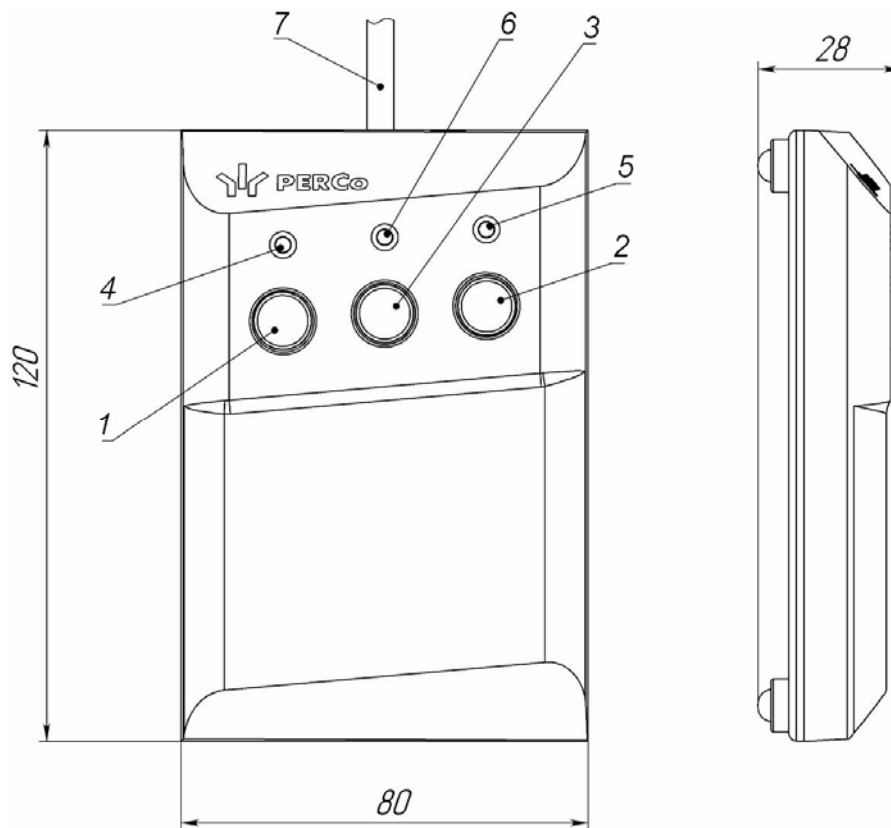

**Figure 4. General view and dimensions of the RC panel**

- 1, 2, 3 – **LEFT, RIGHT, STOP** buttons for mode setting;
- 4, 5 – green indicators «Left», «Right»;
- 6 – red indicator «Stop»;
- 7 – cable

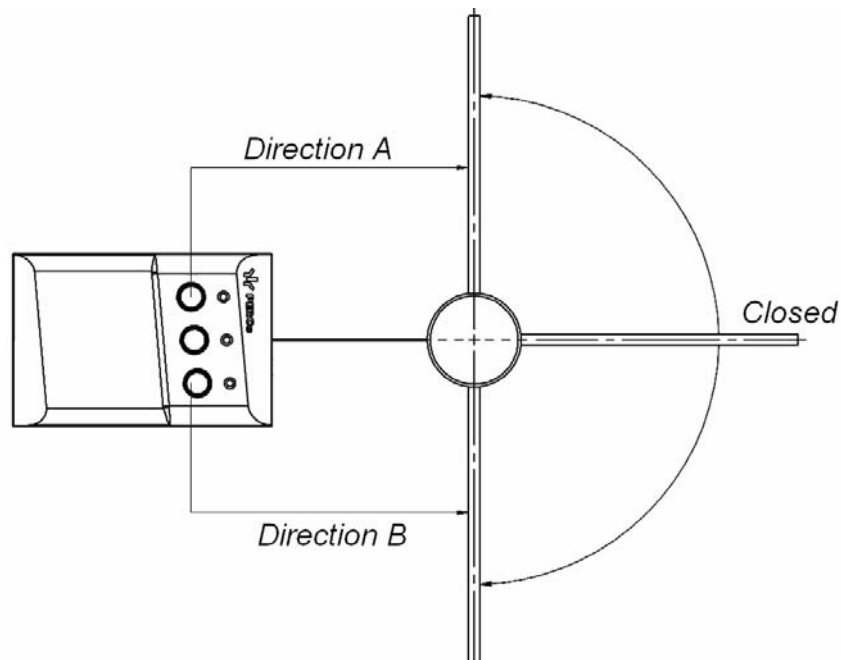

**Figure 5. Standard orientation of RC panel in relation to gate opening direction**

**Table 2. Connection of RC panel cable to XT2 connector block in standard and reversed orientation of the RC panel**

Number	Title	Orientation	
		Standard	Reversed
1	<i>Fire Alarm</i>	-	-
2	<i>GND</i>	-	-
3	<i>GND</i>	black	black
4	<i>Unlock A</i>	white	green
5	<i>Stop</i>	blue	blue
6	<i>Unlock B</i>	green	white
7	<i>Led A</i>	yellow	red
8	<i>Stop</i>	orange	orange
9	<i>Led B</i>	red	yellow
10	<i>Sound</i>	brown	brown

## 5.4 Parameters of input and output signals

The microcontroller installed on the control board tracks the status of *Unlock A*, *Stop*, *Unlock B* and *Fire Alarm control* input signals, and also tracks output signals from rotation sensor.

Upon data receiving the microcontroller creates commands to the control mechanism of the gate, and also signals for connected external indication devices, indication on the RC panel (*Led A*, *Led Stop* and *Led B*), signals on the performed rotation of the swing panel on outputs *Pass A* and *Pass B*.

### Inputs for control devices connection

The swing gate can be operated with RC panel, WRC device or ACS controller.

A device that sends *Fire Alarm* signal is used for emergency unblocking of passage.



#### **Note:**

Control devices (RC panel, WRC device, ACS controller) can be connected separately or in any combination with each other.

In case of combined connection the overlapping of signals send by control devices may occur. In such case the reaction of the gate will correspond with the reaction towards the generated combination of input signals.

Control devices are connected to *Unlock A*, *Stop* and *Unlock B* control inputs. The gate is operated by input of a low-level signal to *Unlock A*, *Stop*, *Unlock B* contacts with *GND* contact of **XT2** connector block. Algorithms of control signals sending are given in Appendices A and B.

A normally open relay contact or open collector output scheme can be used as a control element (see Figure 6 and Figure 7).

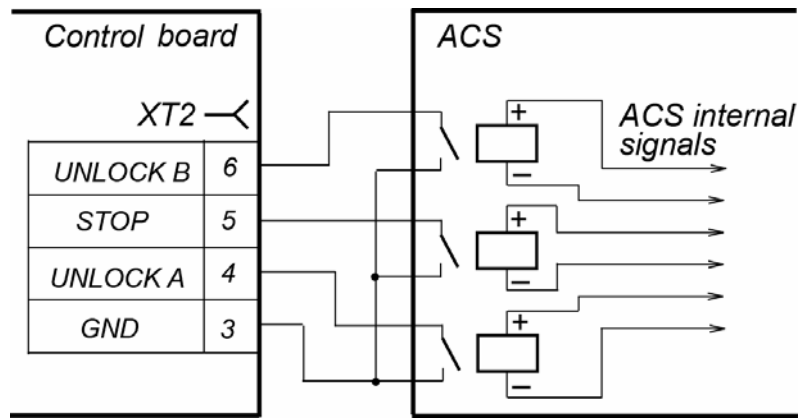

**Figure 6. ACS control element, normally open relay contact**

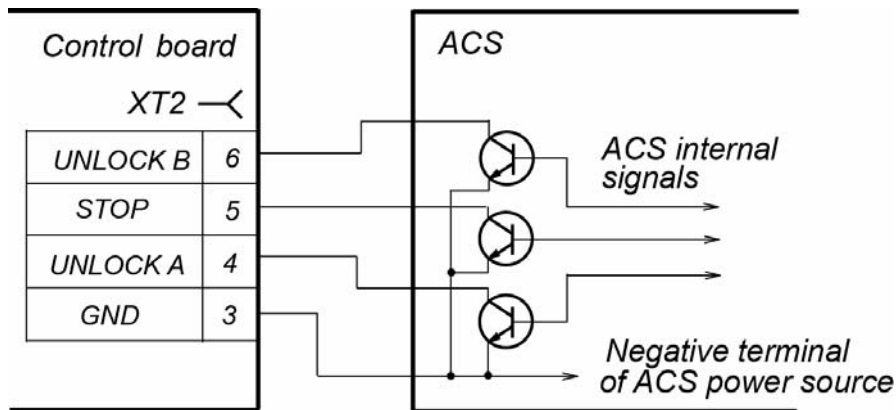

**Figure 7. ACS control element, open drain output scheme**

The device that sends *Fire Alarm* emergency unblocking signal is connected to *Fire Alarm* control input. Emergency unblocking is performed by turn-off of the low-level signal at *Fire Alarm* contact and *GND* contact on **XT2** connector block. In such case normally closed contact or open collector output scheme may be used as control element.

If *Fire Alarm* input is not used, it is necessary to install a jumper between *Fire Alarm* and *GND* contacts on **XT2** connector block. The jumper is installed on default.

The gate can be operated in two control modes: pulse and potential. The control mode is set by installing or removing of the jumper on **Imp/ Pot** connector. If the jumper is installed, the gate is operated in pulse control mode; if the jumper is removed, the gate is operated in potential control mode. The jumper is installed on default. Algorithms of control signals sending for each control mode are given in Appendix.

Connection of devices to control inputs is performed in accordance with electrical connection layout, shown in Fig. 11.



**Note:**

To create high-level signal on all input contacts (*Unlock A*, *Stop*, *Unlock B*, *Fire Alarm*) resistors with 2 kOhm connected to + 5 V power line are used.

Control element shall provide the following specifications of signals:

control element – relay contact:

- minimum switching current .....max. 2 mA
- resistance of closed contact  
(including resistance of connection cable) ..... max. 300 Ohm

control element – open collector output scheme:

- voltage at the closed contact  
(low-level signal, at the input of the control board) .....max. 0.8 V

**PASS outputs**

*PASS A* (*Pass A* and *Common* contacts of **XT1** connector block), *PASS B* (*Pass B* and *Common* contacts of **XT1** connector block) outputs are basically a relay.

If the power is turned off, control board relays are normally open. In such case *Common* contact is not connected to the negative terminal of the gate's power supply (see Fig. 8).

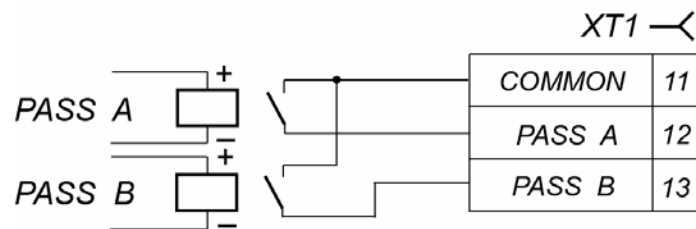

**Figure 8. Output stages for PASS A, PASS B**

If the status is normalized and the power is turned on, relay coil is energized and *PASS A*, *PASS B* relay contacts are closed.

*PASS A*, *PASS B* relays activation/deactivation can be defined by activation/deactivation of indicators that are installed near related outputs on the control board (see Fig. 3).

Output stages for *PASS A*, *PASS B* relay contacts have the following signal specifications:

- maximum switching DC voltage ..... 42 V
- maximum switching current ..... 0.25 A
- resistance of closed contact ..... max. 0.15 Ohm

**Outputs for external indication connection**

*Light A* and *Light B* outputs are used for external indication connection and are basically relay transfer contacts (see Fig. 9). Each output has full contact set on **XT1** connector block: normally open (NO), normally closed (NC) and common (C). Connection is performed in accordance with electrical connection layout given in Fig. 11.

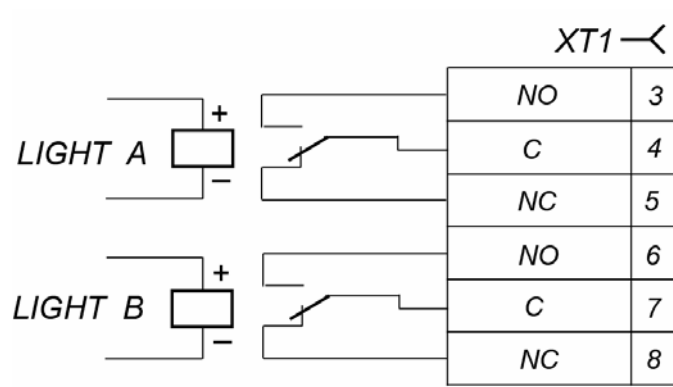

**Figure 9. Output stages for Light A and Light B**

*Light A* (*Light B*) relay is activated (meaning that its coil is energized) when the passage is open in direction A (B) and normalized when the passage is closed in the related direction.

*Light A* (*Light B*) relays activation/deactivation can be defined by activation/deactivation of indicators that are installed by near related outputs on the control board.

Output stages for *Light A* (*Light B*) are relay transfer contacts with the following signal specifications:

maximum switching DC voltage .....	30 V
maximum switching AC voltage .....	42 V
maximum switching AC / DC .....	3 A
resistance of closed contact .....	max. 0.15 Ohm

## 5.5 Operation contingences during gate operation

In case of any impediment to the free rotation of the swing gate an automatic switch to overload mode is provided. The mode is used to avoid damage to electromechanical elements due to overheating.

If any obstacle impedes rotation of the swing panel three attempts of rotation in the same direction are made with 3 sec intervals. If the obstacle remains the swing gate is switched into overload mode. Being in the overload mode the swing panel can be rotated free by  $\pm 90^\circ$  angle that allows removing the obstacle. In such case all three indicators on the RC panel are blinking, and a sound indication consisting of three short audio signals is turned on each 20 sec.

The overload mode is switched off by rotating of the swing panel into “*Closed*” position manually or by turning the power supply off and them on (in this case the gate will be set into initial position automatically).

## 6 MARKING AND PACKAGING

The swing gate has a marking in the form of label located inside rotary post under the cover. The label contains trademark and contact details of the manufacturer, the manufacture date, power voltage and power consumption. To get access to the marking take off the post cover by unscrewing three 3 screws using S1.5 wrench.

The swing gate in the standard package is packed in two boxes that protect it from being damaged during transportation and storage. The box 1 contains gate post and RC panel, the box 2 contains swing panel. Boxes have the marking of the packed product and additional marking in accordance with design documents and delivery set.

Dimensions, (L × W × H):

box 1 .....	121×23×26 cm
box 2 for <b>AGG-650</b> glass panel .....	96×12×90 cm
box 2 for <b>AGG-900</b> glass panel .....	121×12×90 cm

Gross weight:

box 1 .....	max. 33 kg
box 2 for <b>AGG-650</b> swing panel .....	max. 28 kg
box 2 for <b>AGG-900</b> swing panel .....	max. 35 kg



## 7 SAFETY REQUIREMENTS

### 7.1 Installation safety

Installation should be performed by qualified personnel only, in strict accordance with the Manual and general electrical safety requirements for electrical and installation work.



#### **Attention!**

- All the connections should be performed only after the control unit is disconnected from the power supply.
- Only serviceable tools should be used.
- Cables should be laid in accordance with electrical safety requirements.
- Before first activation of the gate check whether the installation and all connections are performed correctly.

The installation of power supply unit shall be performed in accordance with general safety requirements given in its operation manual.

### 7.2 Operation safety

Observe general safety requirements for use of electrical equipment.



#### **Warning!**

- Do not use the swing gate in environment different from those given in Section 2.
- Do not use the swing gate with power supply unit different from those given in Section 3.

Power supply unit shall be operated in accordance with general safety requirements given in its operation manual.

## 8 ASSEMBLY AND INSTALLATION

Observe safety requirements given in Section 7.1 during installation.

### 8.1 General recommendations

Proper installation is critical to performance and serviceability of the swing gate. We advise you to study this Manual before installation work and follow the instructions to the latter.

We recommend:

- to mount the swing gate on flat, solid concrete floors (grade 400 or higher), stone or similar foundations at least 150 mm thick.
- to make sure the mounting foundation is horizontal and flat, so that all the mount points lie in the same plane;
- to employ reinforcing elements 450×450×200 mm for softer grounds.

### 8.2 Tools and equipment required for installation

Use the following tools for the installation works:

- 1.2÷1.5kW hammer drill;
- Ø16 mm hard-alloy drill bits for anchor bolts sleeves;
- Phillips head screwdriver №1;
- allen key S1.5;
- open-end wrench S17;
- hobby knife;
- level;
- measuring tape 2 m.



**Note:**

The use of different tools is acceptable on condition that they do not reduce the quality of installation works.

### 8.3 Appropriate length of cables

Maximum acceptable length RC panel / ACS controller cable ..... 30 m

Maximum acceptable length of power supply cable depends on it cross-section and shall be as following:

- for 1.5 mm<sup>2</sup> cross-section (AWG 15) ..... max. 10 m
- for 2.5 mm<sup>2</sup> cross-section (AWG 13) ..... max. 20 m

## 8.4 Installation sequence



### **Attention!**

The manufacturer shall not be liable for any damage caused in the result of improper installation and declines any claims arising thereof in case if the installation is not in compliance with the instructions provided in this Manual.

Item numbers in the installation sequence are given according to Fig. 2, unless stated otherwise. Electrical connection layout is given in Fig. 11. Location of connector blocks and jumpers on the control board is given in Fig. 3. Cables used for installation and their maximum length are set in Section 8.3. Recommendations on surface preparation are given in Section 8.1. Follow this sequence during gate installation:

1. Unpack the box with equipment, check carefully the delivery set according to Section 4.



### **Attention!**

Don't hold the gate by its cover (3) while moving it.

2. Mark and prepare the mounting holes in the floor as per Fig. 10 for anchors (9) to install the gate post (If necessary, take advantage of the supplied template). Use  $\varnothing 16$  mm hard-alloy drill for hole preparation. Drilling depth is 60 mm.

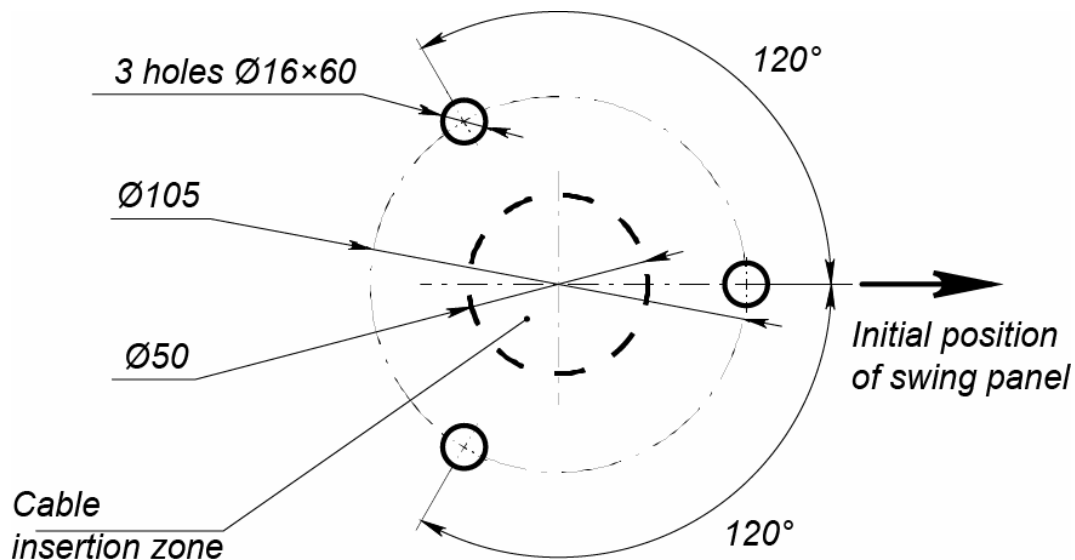

**Figure 10. Mounting hole pattern**

3. Install power supply unit in accordance with its operation manual.
4. If it is necessary to lay power cables (13) and control cables (14) under the floor, prepare an electrical conduit in the floor in the zone where cables are inserted into the gate post. Location of the zone is given in Fig. 10.
5. Install anchors in the drilled holes in the floor, so that their shells would not obtrude out of the floor surface.

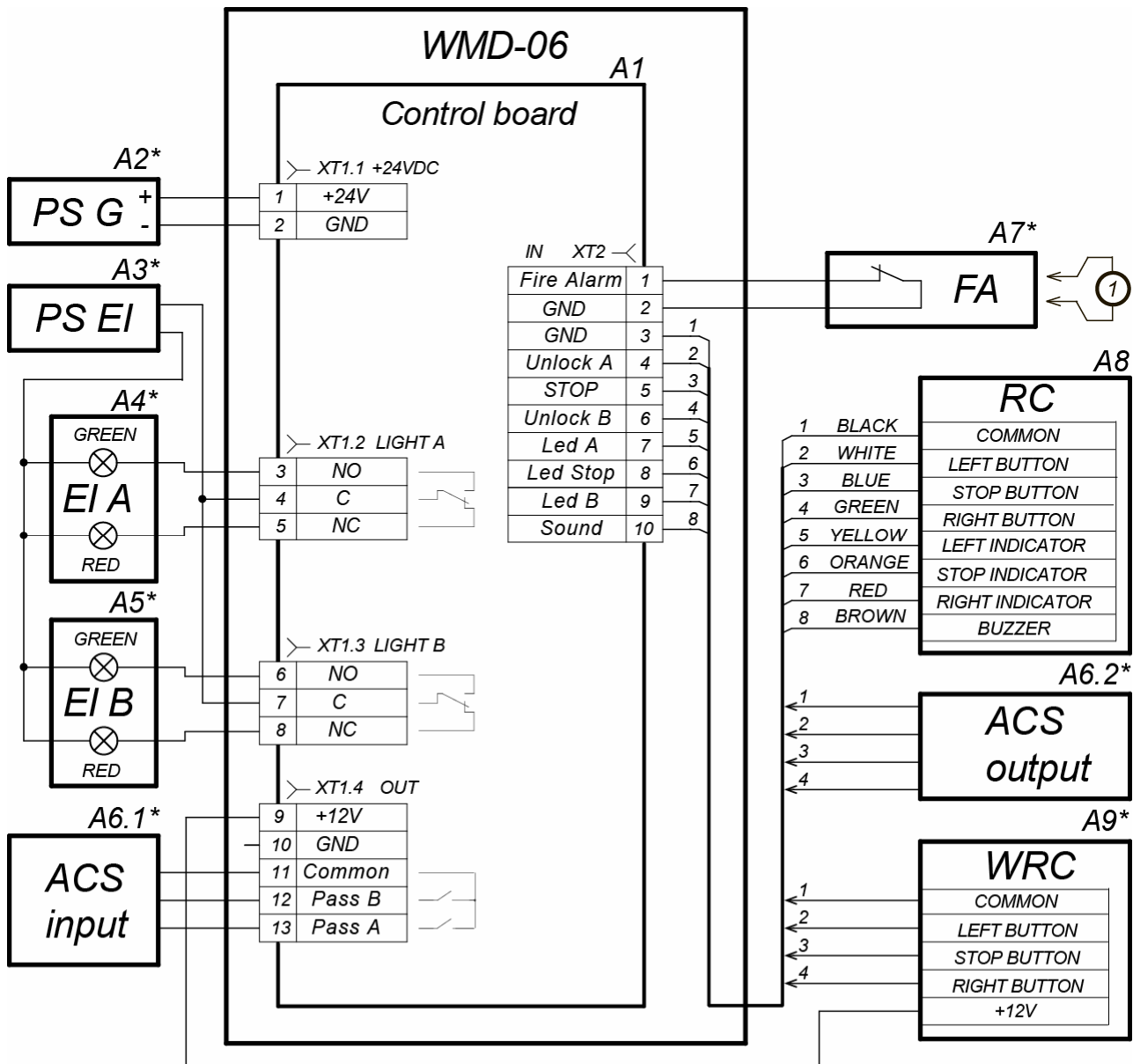

Figure 11. Electrical connection layout

Table 3. List of elements of electrical connection layout

Legend	Item	Comments
A1	Control board	
A2*	Power supply unit of the swing gate	+24V DC; 4A
A3*	Power supply unit of external indicators	
A4*, A5*	External indicator	
A6.1*	ACS controller input	
A6.2*	ACS controller output	
A7*	Device sending <i>Fire Alarm (FA)</i> emergency unblocking signal	
A8	RC panel	PERCo-H6/4
A9*	WRC device	MSRF-4
1	Wire jumper. Installed when the emergency unblocking device (A7) is not connected.	Installed on default

\* Not included in standard delivery set.

6. Unscrew screws (8) and take off the cover (3) of the gate post.
7. Take off the housing (2) and the metal ring (5) by moving it up carefully along the axis of the post.
8. Lay power cable and control cable inside electrical conduit towards cable insertion zone. Pull cables inside the stationary base (1) to the length appropriate for following installation on the control board (6).



**Attention!**

Install and fix the gate post only when all cables are laid inside electrical conduit and the gate post. Be careful until the post is not fixed, prevent it from falling down.

9. Install the gate post on anchors (9). Put it vertically by using a lever. Mounting pads may be used. Vertical deviation shall not exceed  $0.5^\circ$  in two planes.
10. Put a washer (11) on each anchor and fix the gate post with three nuts M10 (10).
11. Connect power cable and control cable to **XT1** and **XT2** connector blocks of the control board (6). Put cables as shown in Fig. 3.
12. In case of necessity connect *Fire Alarm* emergency unblocking device. If the device is not connected, a wire jumper shall be installed on *Fire Alarm* and *GND* contacts on **XT2** connector block.
13. If it is necessary, connect external indicators to **XT1.2** and **XT1.3** connector blocks.
14. If it is necessary, change the position of jumpers on the control board.
15. Mount the glass panel according to Fig. 12. Fix the panel (6) on the rotary support (7) with elements (1) – (5).



**Attention!**

Be careful while mounting the glass panel, prevent it from falling and hitting by metal elements of the post. Due to the significant weight of the panel, it is recommended to put a support under it during the assembly.

16. Install the metal ring, the housing and the cover on the gate post in the order reverse to disassembly order.

When the installation is finished turn the gate on and tests its operation in accordance with Section 9.1.

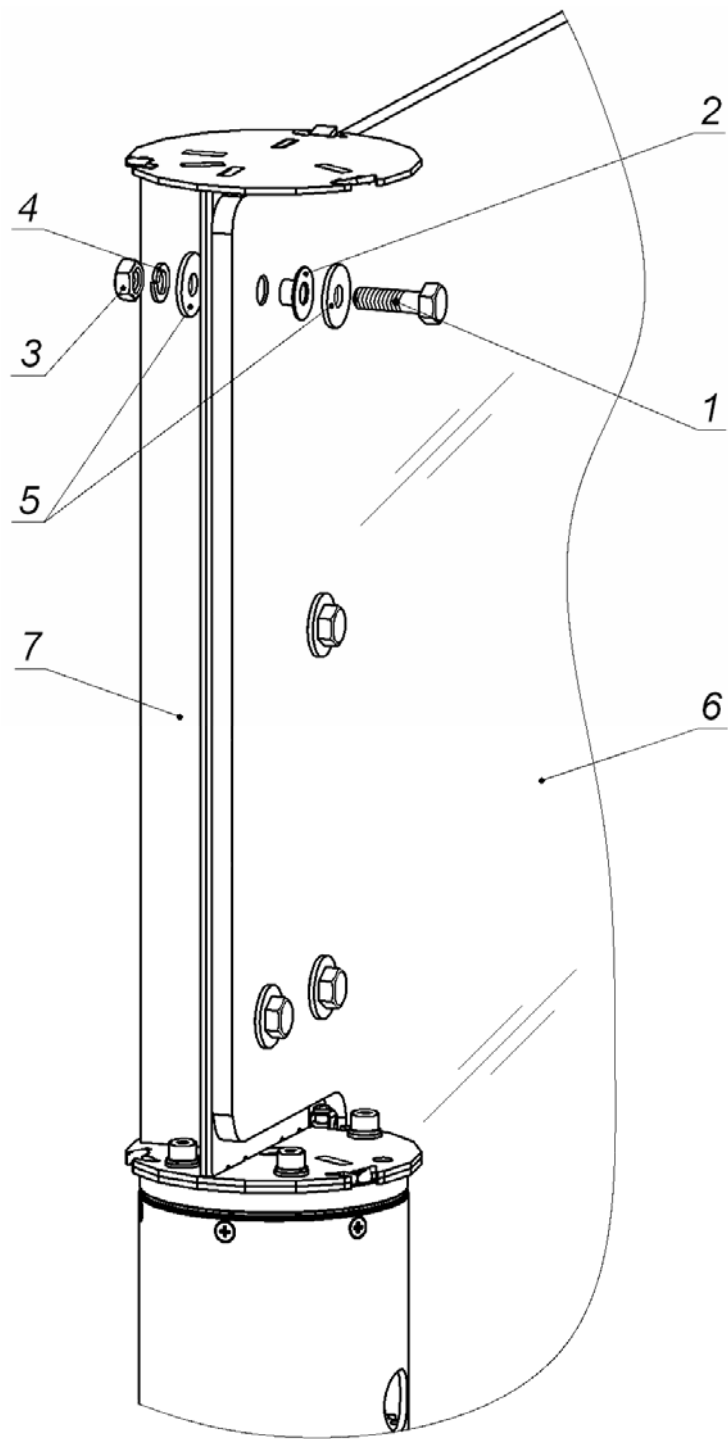

**Figure 12. Glass panel mounting**

- 1 – bolt M10; 2 – plastic bushing; 3 – nut M10;
- 4 – spring washer; 5 – expanded washer; 6 – glass panel;
- 7 – rotary support

## 9 OPERATION

Observe safety requirements given in Section 7.2.



### **Warning!**

- Do not move any objects through the passageway dimensions of which exceed the width of the passageway.
- Do not hit elements of the swing gate so as to prevent their mechanical damage.
- Do not dismantle or adjust mechanisms ensuring operation of the swing gate.
- Do not use substances for cleaning of the swing gate that may cause mechanical damage or corrosion of the surfaces.

### 9.1 Power-up



#### **Attention!**

Make sure that there are no obstacles in the rotation zone and passageway of the gate before starting the power-up.

Perform the following actions in order:

1. Connect the network cable of the power supply unit to electric network socket with voltage and frequency set in the certificate of the power supply unit.
2. Turn the power supply unit on.
3. The swing gate will detect “*Closed*” position in automatic mode (see Figure 5).
4. If the pulse control mode is set, the swing gate will set in “*Always locked*” mode, if the potential mode is set; the swing gate will set in “*Locked for entry and exit*” mode. The red indicator located above **STOP** button on the RC panel will turn on.

The swing gate is ready for operation.

### 9.2 Pulse control mode

Pulse control mode is used to operate the swing gate with RC panel, WRC devices and ACS controllers that support this mode.

Setting of pass modes is performed by a low-level signal or by closing of *Unlock A*, *Stop*, *Unlock B* contacts with *GND* contact of **XT2** connector block. In such case the duration of the control signal shall be at least 100 ms. Algorithm of control signals is given in Appendix A. Indication of the RC panel and position of the swing panel are given in Table 4.

The gate stays open for 4 sec in “*Single passage in chosen direction*” mode. Timing starts after the swing panel is rotated by 85° angle. After that the swing panel moves to “*Closed*” position and blocks, the swing gate sets in “*Always locked*” mode.

“*Single passage in chosen direction*” mode can be changed to “*Always free*” mode in the same direction or to “*Always locked*” mode; “*Always free*” mode can be changed to “*Always locked*” mode only.

**Table 4. Operation modes in pulse control mode  
(jumper on Imp/Pot connector is installed)**

Operation mode	Your actions on RC panel	RC panel indication	Panel position
“Always locked”	Press <b>STOP</b> button.	Red indicator above <b>STOP</b> button	Panel sets in “Closed” position and blocks
“Single passage in chosen direction”	Press <b>LEFT</b> or <b>RIGHT</b> button corresponding to the chosen passage direction.	Green indicator above the button responsible for the chosen passage direction, red indicator above the <b>STOP</b> button	Panel opens in chosen direction for a single passage
“Always free”	Press the <b>STOP</b> button and the button corresponding to the chosen passage direction simultaneously	Green indicator above one of the buttons responsible for the passage direction	Panel opens in one of the directions and remains in this position until the mode is changed.

### 9.3 Potential control mode

Potential control mode is used to operate the swing gate with ACS controllers that support this mode.

Setting of operation modes is performed by continuing low-level signal on *Unlock A*, *Stop* and *Unlock B* contacts and *GND* contact on **XT2** connector block. Algorithm of control signals is given in Appendix B. Indication of the RC panel and position of the swing panel are given in Table 5.

The duration of waiting period for “*Direction open*” mode is defined by the duration of control signal on the contact related to opening direction of the swing panel.

**Table 5. Operation modes in potential control mode  
(jumper on Imp/Pot connector is removed)**

Operation mode	Provided signal	Your actions on RC panel	RC panel indication	Panel position
“Both directions closed”	Low-level – on <i>Stop</i> contact, high-level – on <i>Unlock A</i> and <i>Unlock B</i> contacts.	Press and hold <b>STOP</b> button	Red indicator above <b>STOP</b> button	Panel sets in “Closed” position
“ <i>Direction open</i> ”	Low-level – on <i>Unlock A</i> or <i>Unlock B</i> contact (corresponding to the chosen passage direction), high-level – on other contacts <i>Stop</i> , <i>Unlock B</i> ( <i>Stop</i> , <i>Unlock A</i> ).	Press and hold <b>LEFT</b> button or <b>RIGHT</b> button, corresponding to the chosen passage direction	Green indicator above the button responsible for the chosen passage direction	Panel opens in chosen direction and remains in it until the low-level signal on the corresponding contact is turned off



## 9.4 Emergency situations

In case of fire, disasters and any other emergency situations it is necessary to provide emergency exit to evacuate people. For example **BH-02** “anti-panic” rotary sections can be used as an emergency exit.

The passageway of the swing gate can be used as an additional emergency exit. The construction of the gate allows the provision of free exit without use of any special keys or tools. Apply *Fire Alarm* control signal to the control board. The swing panel will open automatically making the passage free regardless to the set operation mode. Other control commands will be ignored. The opening direction is defined by **FireAlarmDir** jumper on the control board. When the signal is turned off, the swing panel moves to “Closed” position and blocks.

Device sending *Fire Alarm* emergency unblocking signal is not included into standard delivery set.

Besides this the swing gate is basically a normally open device, meaning that in case of power failure the swing panel can be rotated manually by  $\pm 90^\circ$  angle, making the passage free.

## 9.5 Troubleshooting

Possible faults to be corrected by the user themselves are listed in Table 6. In an unlikely event of other faults please consult the **PERCo** Technical Support Department.

**Table 6. Troubleshooting guide**

Fault	Most plausible cause	Remedy
When powered-up, indication of RC panel does not work.	No supply voltage on control board	De-energize power supply unit. Remove cover and housing of the gate. Check power cable and its attachment to <b>XT1</b> connector block.
The gate cannot be operated in one of the directions, indication of RC panel works	Control signal of chosen direction is not applied to control board	De-energize power supply unit. Remove cover and housing of the gate. Check cable of RC panel / WRC device / ACS controller and its attachment to <b>XT2</b> connector block

## **10 MAINTENANCE**

Technical maintenance of the swing gate should be performed only at **PERCo** service centre.

We recommend using liquid non-abrasive cleansers containing ammonia to clean a swing gate post and a glass panel when dirty.

## **11 TRANSPORTATION AND STORAGE**

The swing gate in the original package should be transported only in closed freight containers or other closed type cargo transport units.

During storage and transportation boxes with swing gate posts can be stacked no more than 2 layers high. Stacking of boxes with glass panels is not allowed.

The swing gate should be stored in dry indoor facilities at ambient temperatures between – 40°C and +45°C and at relative air humidity of up to 98% at +25°C.

After transportation or storage at below-zero temperatures or high air humidity, the swing gate should be kept unpacked for minimum 24 hours under normal climate conditions corresponding to operation conditions.

## APPENDIX A. Control signal algorithm in pulse control mode

The command is a signal active front (signal transfer from the high level to the low level) at any of the contacts at presence of the corresponding signal levels at the other contacts.



**Note:**

RC panel:

- active front – pressing of the relevant button,
- low level – the relevant button has been pressed,
- high level – the relevant button has not been pressed.

The following commands can be formed by sending a low-level signal to *Unlock A*, *Stop* and *Unlock B* contacts and *GND* contact on the **XT2** connector block relatively to the contact *GND*:

**Always locked (locked for entry and exit)** - active front is at the contact *Stop* while there is a high level at the contacts *Unlock A* and *Unlock B*. Both passage directions are locked at this command.

**Single passage in the direction A (open for passage of one person in the direction A)** - active front is at the contact *Unlock A* while there is a high level at the contacts *Stop* and *Unlock B*. At this command the passage direction A opens either for 5 sec. or until the passage has been made in this direction or until the command “*Always locked*”, and the status of the passage direction B does not change at that. The command is ignored if at the moment of its receipt the status of the passage direction A is “*Always free*”.

**Single passage in the direction B (open for passage of one person in the direction B)** - active front is at the contact *Unlock B* while there is a high level at the contacts *Stop* and *Unlock A*. At this command the passage direction B opens either for 5 sec. or until the passage has been effected in this direction or until the command “*Always locked*”, and the status of the passage direction A does not change. The command is ignored if at the moment of its receipt the status of passage direction B is “*Always free*”.

**Free passage in the direction A (open for free passage in the direction A)** - active front is at the contact *Unlock A* while there is a low level at the contact *Stop* and a high level at the contact *Unlock B*, or active front is at the contact *Stop* while there is a low level at the contact *Unlock A* and a high level at the contact *Unlock B*. At this command the passage direction A opens until the command “*Always locked*” is received; the status of the passage direction B does not change at that.

**Free passage in the direction B (open for free passage in the direction B)** - active front is at the contact *Unlock B* while there is a low level at the contact *Stop* and a high level at the contact *Unlock A*, or active front is at the contact *Stop* while there is a low level at the contact *Unlock B* and a high level at contact *Unlock A*. At this command the passage direction B opens until the command “*Always locked*” is received; the status of the passage direction A does not change at that.

## APPENDIX B. Control signal algorithm in potential control mode



### Note:

For ACS controller outputs:

- high level – either contacts of the output relay are broken or the output transistor is closed,
- low level – either contacts of the output relay are closed or the output transistor is open.

**Both directions are locked (locked for entry and exit)** - there is a high level at the contacts *Unlock A* and *Unlock B*, or a low level at the contact *Stop*. The both passage directions are locked at this command.

**The direction A is open (open for passage in the direction A)** - there is a low level at the contact *Unlock A* while a high level is present at the contacts *Stop* and *Unlock B*. At this command the direction A is opened till the low-level signal removal from the contact *Unlock A* or until the command "*Both directions locked*" is received. The status of the direction B does not change at that.

**The direction B is open (open for passage in the direction B)** - there is a low level at the contact *Unlock B* while there is a high level at the contacts *Stop* and *Unlock A*. At this command the direction B is opened till the low-level signal removal from the contact *Unlock B* or until the command "*Both directions locked*" is received. The status of the direction A does not change at that.

# **PERCo**

Polytechnicheskaya str., 4, block 2  
194021, Saint Petersburg  
Russia

Tel: +7 812 247 04 64

**E-mail: [export@perco.com](mailto:export@perco.com)  
[support@perco.com](mailto:support@perco.com)**

**[www.perco.com](http://www.perco.com)**



[www.perco.com](http://www.perco.com)