



Full Height Security Gate

WHD-15

INSTALLATION AND OPERATION MANUAL



CE



Full Height Security Gate

WHD-15

Installation and Operation Manual

CONTENT

1	APPLICATION	3
2	OPERATION CONDITIONS.....	3
3	TECHNICAL SPECIFICATIONS	3
4	DELIVERY SET.....	4
4.1	Standard delivery set.....	4
4.2	Optional equipment and mounting hardware.....	4
5	DESIGN AND OPERATION	5
5.1	Main features.....	5
5.2	Design and operation	5
6	MARKING AND PACKAGING.....	8
7	SAFETY REQUIREMENTS.....	8
8	INSTALLATION.....	9
8.1	Main guidelines.....	9
8.2	Installation of the gate	9
8.3	Installation of standard and optional equipment	10
8.4	Installation checkup	11
9	TRANSPORTATION AND STORAGE	11

Dear customers!

*We thank You for choosing the turnstile manufactured by PERCo.
You have purchased a high quality product, which will be long lasting
in operation provided that installation and operation rules are observed.*

The Installation and Operation Manual (hereinafter – the Manual) contains the instructions you need for safety transportation, storage, installation, operation, and maintenance of the **WHD-15 full height security gate** (hereinafter – the gate).

The product installation should be carried out with strict accordance to this Manual.

1 APPLICATION

The gate is designed for management of pedestrian flows and access control at entrance points of facilities and areas with high security requirements and necessity for full vertical closure of the passageway.

It is advisable to determine the number of the gates sufficient for fast and convenient pedestrian passage through the entrance point on basis of the gate throughput capacity (sect. 3 of the Manual).

2 OPERATION CONDITIONS

The gate, in accordance with the resistance to environmental exposure, complies with GOST 15150-69, category N2 (outdoor operation).

Operation of the gate is allowed at ambient temperature from –30°C to +40°C and relative air humidity of up to 98% at +25°C.

3 TECHNICAL SPECIFICATIONS

Throughput rate in the single passage mode	12 persons/min
Average daily throughput in the single passage mode	2,000 persons/day
Passageway dimensions (H x W)	2110x950 mm
Mean time to failure	min. 1,000,000 passages
Mean lifetime	min. 8 years
Overall dimensions (H x W x D)	1232x378.5x2150 mm
Net weight	max. 42 kg

4 DELIVERY SET

4.1 Standard delivery set

Primary parts:

Assembled gate with rim electric lock	1
Set of keys to electric lock.....	1
Door closer with fasteners.....	1

Assembling tools:

Hex key S4	1
------------------	---

Technical documentation:

Gate installation and operation manual	1
Gate certificate	1
Door closer installation and operation instructions	1
Electric rim lock installation and operation instructions	1

Package:

Box	1
-----------	---

4.2 Optional equipment and mounting hardware

The following optional equipment and assembling tools could be included in the delivery set on request:

- MB-15 full height railing sections ¹;
- Fasteners ².
- SORMAT PFG IR 12-20 anchor bolts³4



Note:

Technical characteristics of optional equipment are given in the respective documentation included in the delivery set of each optional product.

¹ Quantity determined by the customer.

² Plates and brackets to join the gate with the **RTD-15** turnstile, the **MB-15** railing section or a wall. Types, number and mounting order of the fasteners depend on the entrance point design and are set out in the installation documentation for a particular combined order, beyond the scope of this Manual.

³ For solid concrete floors or similar foundations (see sect. 8.2.3). Installation of the gate on other types of foundations may require different mounting hardware.

5 DESIGN AND OPERATION

5.1 Main features

The gate meets current requirements to such equipment in compliance with GOST P 51241. Main features of the gate are as follows:

- possibility of **remote** gate unlocking;
- **leaf reset** by a hydraulic door closer after the passage;
- **wide passageway** to provide controlled passage for people in wheelchairs (with an attendant) and deliveries of large or bulky items;
- **low-weight leaf** for comfortable passage;
- aluminium-alloy structure with **high resistance to corrosion** guarantees long life operation even in unfavourable environments;
- **durable polymeric powder coating** protects the outside appearance;
- **unity of design** with **RTD-15** full height turnstiles and **MB-15** railings enables various configurations of the entrance point to meet any required layout and dimensions;
- together with **RTD-15** full height turnstiles, the gate can be used as an **emergency exit**.

5.2 Design and operation

The gate design is shown in Fig. 1.

Unless noted otherwise, the position numbers in the Manual agree with Fig.1.

Overall dimensions of the gate are given in Fig. 2.

The gate consists of:

- a frame (1);
- a leaf (2);
- an electric lock (3);
- a door closer (4).

The *frame* (1) consisting of three joined vertical posts and *the leaf* (2) are made of durable aluminium profile. The assembled gate is delivered with the *rim electric lock* (3) mounted on the frame. During the installation, the hydraulic *door closer* (4) is mounted on the frame and the leaf. The gate is mounted on the floor with anchor bolts driven through four mounting holes in the post flanges.

In the *home position* the leaf provides complete closure of the passageway between the posts. The leaf opens towards the door closer. Mounting holes for the door closer are made for opening angle of 120°, according to its installation and operation instructions.

The gate *reset state* is «closed for entrance and exit» (the leaf is in the home position, the lock is locked up).

Unlocking is made by ether a mechanical key or a control pushbutton on the lock body. *Locking* is made by automatic latching of the lock when the leaf returns to the home position. (See the installation and operation instructions for the electric lock).

For remote unlocking the lock should be wired to a 12V DC @ 3A power supply unit as per the lock operation instructions through the cabling hole in the gate post.

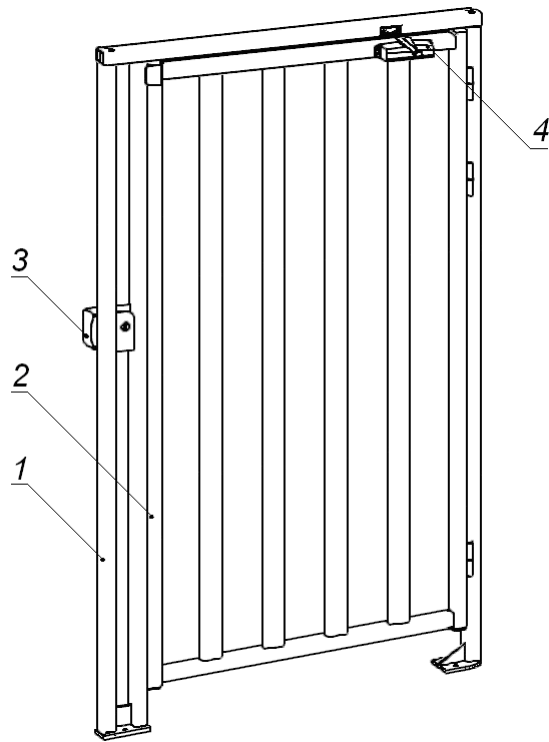

Fig. 1 General view of the WHD-15 gate
1 – frame; 2 – leaf; 3 – electric lock; 4 – door closer

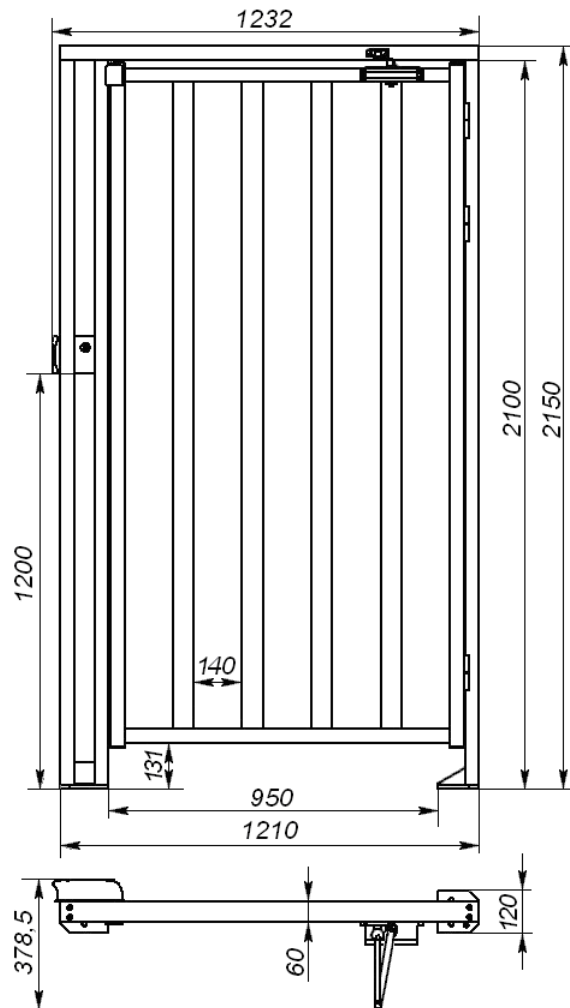

Fig. 2. Overall dimensions of the WHD-15 gate

When the lock is operated from the control pushbutton, it is unlocked by a momentary press of the control pushbutton which gives a potential pulse of minimum 500 ms duration. Once the transmission is over, the lock switches to the «Open» mode and can remain in it indefinitely.

After opening of the leaf and its return to the home position by the door closer, the latch snaps to and makes the unlocking mechanism ready for the next opening.

The gate can be unlocked manually at any time from each side by turn the mechanical key in the lock cylinder.

To open the gate by the key from the lock side of the gate, turn the key anticlockwise as far as it goes and press the control pushbutton. If after that the key is put out, the next unlocking can be made without the key by pressing of the control pushbutton.

If the key is turned clockwise as far as it goes and then put out, the pushbutton operation is blocked and unlocking can be made again only by the key or remotely by control impulse.

To open the gate by the key from the opposite side, turn the key clockwise as far as it goes, unblocking the latch. If after that the key is put out, the next unlocking can be made by either the key or remotely by control impulse.

For correct gate operation from an ACS we advise to mount a compact reed sensor on the gate connecting it to an ACS controller so that to track the «Closed» position of the leaf. The magnet part of the reed sensor should be mounted into the upper part of the leaf while the sensor itself — into the gate post.

6 MARKING AND PACKAGING

The gate marking contains the product name, its date of manufacture and serial number. Optional accessories and items are marked according to their respective technical documentation.

The standard delivery set is packed into a package box to protect the gate from damage during storage and transportation.

Box overall dimensions (L × W × H)2210×1300×221 mm
Grosse weight..... max. 83 kg

7 SAFETY REQUIREMENTS

Installation of the gate should be carried out by qualified personnel ONLY, in strict accordance with this Manual and general safety requirements for electrical and installation work.

In the course of the installation works and operational service:

- use only serviceable tools;
- be particularly careful before the gate is secured in place, prevent it from fall;
- follow safety requirements of operational documentation for the electric lock and the door closer.



WARNING!

No self-dismantling of the door closer is allowed.

Installation and operational service of optional equipment (sect. 4.2) should be carried out in strict accordance with its respective operational documentation.

8 INSTALLATION

8.1 Main guidelines

Proper installation is critical to performance and serviceability of the gate. We strongly advise to study this section before installation work is commenced, and follow the instructions to the letter over the course of the installation.



WARNING!

The manufacturer will not accept liability for any damage to the gate or other equipment, or otherwise loss caused as a result of improper installation, and will dismiss any claims by the customer should the installation work be carried out not in accordance with this Manual.

We advise:

- installation to be carried out by at least two persons qualified in assembly and electric work;
- mounting the gate on flat, solid concrete floors (grade 400 or higher, SCS B22.5), stone or similar foundations at least 150 mm thick;
- employing reinforcing elements 250×250×400 mm for soft grounds;
- making sure the mounting foundation is horizontal and flat; the flatness deviation must not exceed 1.5 mm;
- using relevant mounting hardware for installation on different foundations;
- following guidelines of the door closer installation and operation instructions during its installation (sect. 4.1);
- installing optional equipment in the sequence given in sect. 8.3.

Use the following tools for the installation work:

- 2÷1.5 kW electric perforator;
- Ø 20 mm carbide drill bits;
- S13; S17 horn wrenches;
- S6 hex-nut wrench;
- №2 cross-tip screwdriver, 150 mm;
- №5 straight-slot screwdriver, 150 mm;
- pair of trammels;
- 2 m tape-measure;
- level gauge;
- two stepladders (4 steps or more).



Note:

Use of other similar tools is allowed providing they do not reduce quality of the installation work.

8.2 Installation of the gate

Unpack the gate; check the delivery set against section 4 of the Manual.

Further in this section each installation operation is described in compliance with the above guidelines (sect. 8.1).

Recommendations on how to prepare mounting holes in the foundation (the mounting surface) are given with regard to anchor bolts for solid concrete floors or similar foundations (Table 1). Use relevant mounting hardware for installation on different foundations.

Table 1

Anchor type	Drill bit diameter, mm	Drilling depth, mm	Q-ty
PFG IR 12-20	20	80	4

Mark out on the mounting surface mounting holes for the gate installation according to Fig. 3.

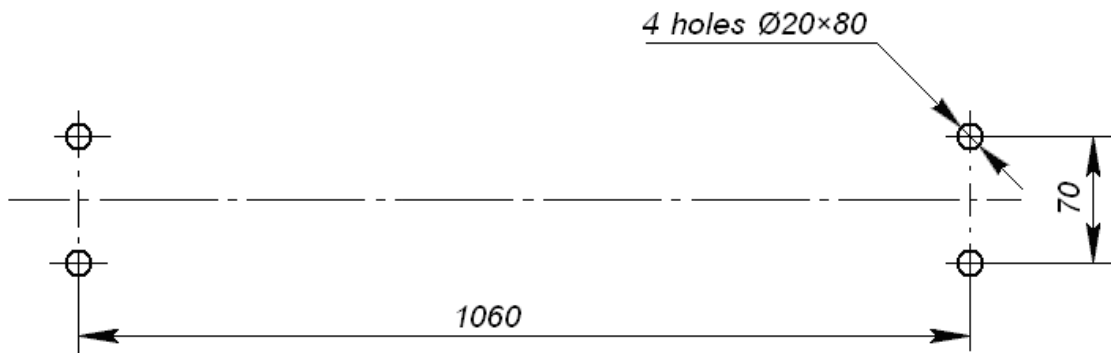

Fig 3. Mounting hole pattern

8.2.5 Prepare the mounting holes for the gate installation. Set the anchors all the way down the prepared holes.



WARNING!

Be extra cautious and careful when carrying out further work, prevent the gate from fall while it is not fixed in place.

Mount the gate so that the flanges are on their respective mounting holes, fix the gate with the anchors observing verticality with a level gauge and using joint liners when necessary.

Install the door closer on the mounting holes in the frame and the leaf. If necessary, adjust the leaf closing speed with the speed-adjusting screws (see installation and operation instructions for the door closer).

8.3 Installation of standard and optional equipment

Seamless integration and unity of design with the RTD-15 series full height rotor turnstiles and the MB-15 series railings enables various configurations of the entrance point to meet any required security level, layout and dimensions.

Carry the installation work in accordance with respective manuals and below guidelines. Exact installation sequence depends on the chosen entrance point layout.

For installation of the gate together with the MB-15 full height railings, we recommend the following installation sequence:

- the gate;
- standard sections of the full height railing;
- extension sections of the full height railing.

For installation of the gate together with the RTD-15 full height rotor turnstiles and the **MB-15** full height railings we recommend the following installation sequence:

- the turnstile foundation frame;
- the turnstile;
- the gate;
- standard sections of the full height railing;

- extension sections of the full height railing;
- the turnstile protective canopy;
- power supply units for the turnstile and the walkway downlights;
- a wireless remote control, remote light indicators, an intrusion detector and a siren.

Contact PERCo Technical Support Department if you need further consulting.

8.4 Installation checkup

Clear the passageway of all foreign objects.

Check operation of the lock and the door closer as per their respective operation instructions (sect. 4.1). After this the gate is ready for service.



DON'TS:

- DO NOT carry through the gate items exceeding the passageway dimensions;
- DO NOT subject the gate to strong impact;
- DO NOT clean the gate with substances that may cause damage or corrosion of its parts.

9 TRANSPORTATION AND STORAGE

The gate in the original package should be transported in closed freight containers or other closed type cargo transport units.

During storage and transportation the boxes can be stacked no more than 2 layers high.

The gate should be stored indoors at ambient temperature from -40°C to $+45^{\circ}\text{C}$ and relative air humidity below 98% at $+25^{\circ}\text{C}$. The environment should be free of acid and alkali vapours or corroding gases.

After transportation or storage of the gate at below-zero temperatures or high air humidity, the installation works should not start before the gate in the original package has been kept for 24 hrs under the environmental conditions referred to in 2 of the Manual.

PERCo

Polytechnicheskaya str., 4, block 2
194021, Saint Petersburg
Russia

Tel: +7 812 247 04 64

**E-mail: export@perco.com
support@perco.com**

www.perco.com



www.perco.com