

PERCo[®]

ASSEMBLY AND OPERATION MANUAL

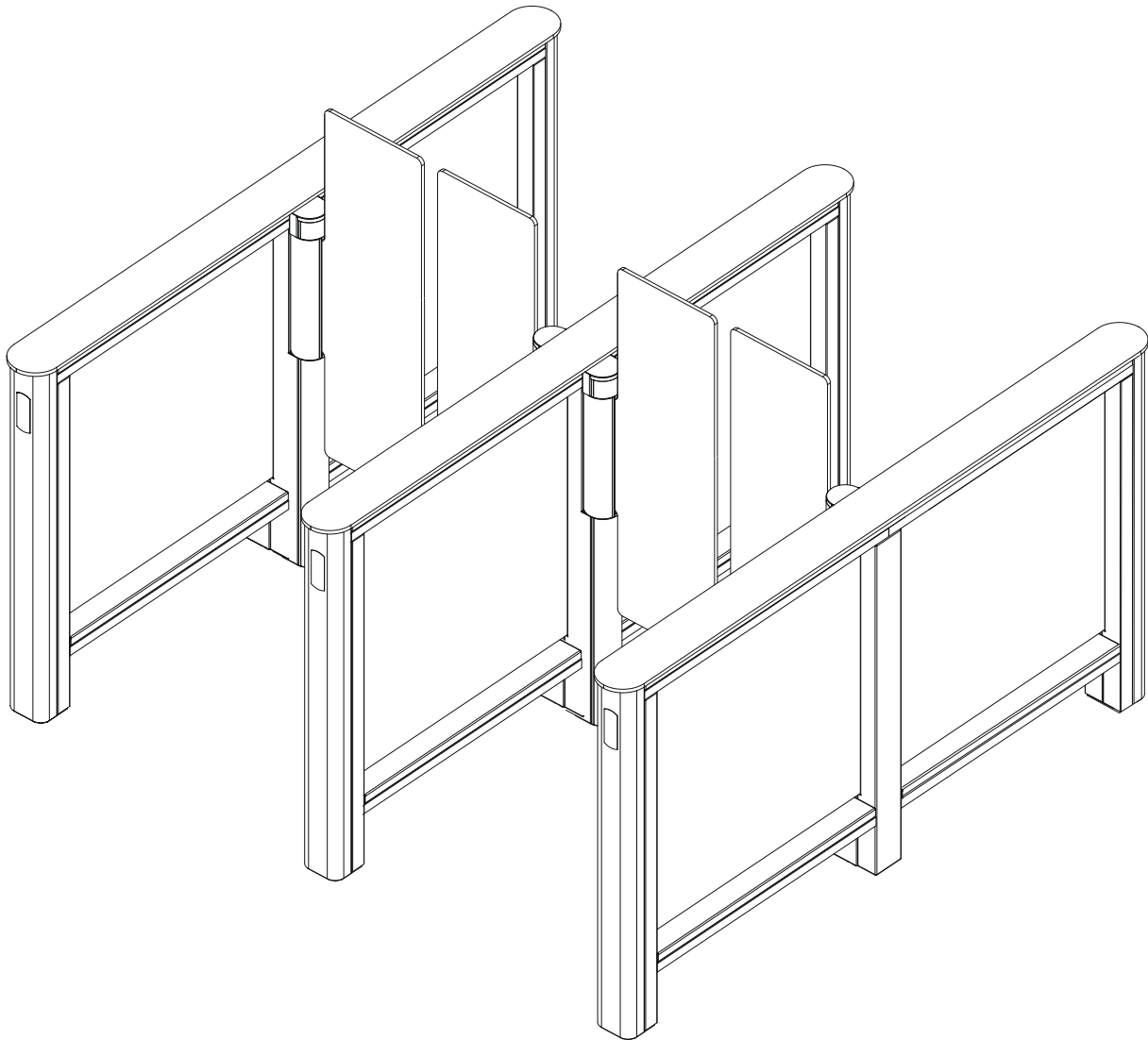

ST-01, STD-01

ERC
CE

SPEED GATE AND DOUBLE-SIDED SECTION

CONTENTS

1	APPLICATION	2
2	OPERATING CONDITIONS	2
3	TECHNICAL SPECIFICATIONS	3
4	DELIVERY SET	4
4.1	Standard delivery set	4
4.1.1	ST-01 Speed gate	4
4.1.2	STD-01 double-sided section	5
4.2	Optional equipment	6
5	DESIGN AND OPERATION	9
5.1	Main features	9
5.2	Design	10
5.2.1	Section	13
5.2.2	Indication blocks	13
5.2.3	RC-panel	14
5.2.4	Control board	14
5.2.5	Control signals	17
5.2.6	Control modes	17
5.2.7	Speed gate operation algorithm	18
5.3	Operating devices	19
5.3.1	RC-panel connection	19
5.3.2	Fire Alarm device	20
5.3.3	Operation from the ACS	20
5.4	Optional devices connected to the speed gate	20
5.4.1	PASS outputs	21
5.4.2	Siren	21
5.4.3	External indication	21
6	MARKING AND PACKAGING	22
7	SAFETY REQUIREMENTS	23
7.1	Installation safety requirements	23
7.2	Operation safety requirements	23
8	INSTALLATION	23
8.1	Installation details	23
8.2	Installation tools	24
8.3	Cable length	24
8.4	Installation order	24
8.5	Mounting surface marking layouts	27
8.6	Speed gate wiring diagram	29
8.7	Training mode	31
8.8	“Auto-opening in the selected direction” mode	31
8.9	Assembly and disassembly of the speed gate components	32
8.9.1	Central post cover plate	32
8.9.2	Front panel of the side post	33
8.9.3	Swing panel	33
8.9.4	Swing panel cover plate	34
8.9.5	Central post indication block	35
8.9.6	Section top cover	36
8.9.7	Bottom duct cover	38
8.9.8	Filling glass	38
9	OPERATION	40
9.1	Power-up	40
9.2	Pulse control mode	40
9.3	Potential control mode	41
9.4	In case of an emergency	41
9.4.1	“Emergency” mode	41
9.4.2	“Fire Alarm” mode	42
9.4.3	Troubleshooting	42
10	MAINTENANCE	42
11	TRANSPORTATION AND STORAGE	42
	Appendix 1. Operation algorithm at pulse control mode	43
	Appendix 2. Operation algorithm at potential control mode	43

Dear Customer!

Thank you for purchasing PERCo product. Please follow instructions given in this Manual carefully and this high-quality product will provide many years of trouble-free use.

Assembly and Operation Manual for the ST-01 Speed gate and STD-01 Double-sided section (hereinafter – *the Manual*) contains the instructions on safe transportation, storage, installation, operation and maintenance of the above-mentioned products. The installation must be carried out by qualified installers in strict accordance with the Manual.

Abbreviations adopted in the Manual:

- ACS – access control system;
- CLB – control logic board;
- PS – power supply;
- RC-panel – remote control panel;
- WRC – wireless remote control;

Due to continuous improvement of products, the Manufacturer reserves the right to modify, without previous notice, the product design not aggravating its technical specifications.

1 APPLICATION

ST-01 Speed gate (hereinafter – the *speed gate*) is designed for pedestrian passage control at entrance points of administrative buildings, banks, shops, railway terminals, airports, etc.



Attention!

ST-01 speed gate is designed for the passage of pedestrians taller than 1 m, otherwise correct operation of the speed gate is not guaranteed. Pass through the speed gate of children less than 1 m height tall can **only be carried by the arm accompanied by adults¹**.

The speed gate features two sections: **ST-01/M** (hereinafter – *Master* section) and **ST-01/S** section (hereinafter – *Slave* section). In a standard delivery set the speed gate allows to arrange one passage lane. The width of the passage lane depends on the chosen swing panel width.

Use **STD-01 double-sided section** (hereinafter – *double-sided section*) to arrange more passage lanes. Each double-sided section provides one extra passage lane.



Note:

Inside the turnstile sections, it is possible to install access card readers as manufactured by **PERCo (IR13, IR19)**, and by third-party manufacturers. The selection of the reader, its purchase and installation into the product are carried out by the customer (installer) in accordance with the checkpoint design and the ACS and controller characteristics. Card readers are not included in the standard delivery set of the turnstile!

Readers must meet the following requirements:

- Overall dimension (length × width × height) max. 155×68×28 mm
- Read range min. 40 mm

2 OPERATING CONDITIONS

The product with regard to resistance to environmental exposure complies with GOST15150-69 category NF4 (operation in premises with climate control).

Operation of the speed gate is allowed at an ambient air temperature from +1°C to +50°C and relative air humidity 80% at +25°C.

¹ If the turnstile is installed in children's institutions or in organizations working with children, where more secure passage mode is required, it is recommended to reflash turnstile controller with a special firmware (*ST01_Children*). Its main feature is the safety zone increased to the whole passage zone of the turnstile and particular operation algorithm when closing swing panels will open if at least one sensor of the turnstile is active.

In order to get necessary recommendations regarding the firmware installation, please contact **PERCo** technical support team.

3 TECHNICAL SPECIFICATIONS

Operating voltage ¹	24±2.4 VDC
Current consumption.....	max. 6.5 A
Power consumption ²	max. 160 W
Throughput rate in a single passage mode	60 persons / min
Passageway width:	
with ATG-300, ATG-300H swing panel	650 mm
with ATG-425, ATG-425H swing panel	900 mm
with ATG-475 swing panel	1000 mm
with ATG-575 swing panel	1200 mm
Number of intrusion detectors:	
upper level	14
lower level	28
RC-panel cable length ³	min. 6.6 m
IP rating	IP41 (EN 60529)
Electric shock protection class	III (IEC 61140)
Mean time to failure	min. 8,000,000 passages
Mean lifetime	8 years
Overall dimensions ⁴ (L × W × H):	
with ATG-300 swing panel	1820×1050×1010 mm
with ATG-300H swing panel	1820×1050×1300 mm
with ATG-425 swing panel	1820×1300×1010 mm
with ATG-425H swing panel	1820×1300×1500 mm
with ATG-475 swing panel	1820×1400×1010 mm
with ATG-575 swing panel	1820×1600×1010 mm



Note:

Use the following formula to calculate the overall speed gate width in case several passage lanes are arranged (Fig. 7): $L_{overall} = 920n + 1170m + 1270k + 1470p + 130$ (mm), where:

- n – number of **ATG-300** and **ATG-300H** swing panel sets installed;
- m – number of **ATG-425** and **ATG-425H** swing panel sets installed;
- k – number of **ATG-475** swing panel sets installed;
- p – number of **ATG-575** swing panel sets installed.

Weight (net):

ST-01/M section	max 85 kg
ST-01/S section	max 85 kg
STD-01 double-sided section	max 100 kg
ATG-300 swing panel	max 6 kg
ATG-300H swing panel	max 9 kg
ATG-425 swing panel	max 8 kg
ATG-425H swing panel	max 15 kg
ATG-475 swing panel	max 9 kg
ATG-575 swing panel	max 11 kg

¹ The power supply is connected to the control board located in the *Master* section (on the *Master* side of the double-sided section) and has the “ST-01.771” marking.

² Current consumption and power consumption are given for each product **ST-01** and **STD-01** individually.

³ Maximum allowable cable length of the RC panel is 40 m (supplied upon request).

⁴ Overall dimensions of the speed gate with different types of panels are shown in Fig. 1 - 7.

4 DELIVERY SET

4.1 Standard delivery set

4.1.1 ST-01 Speed gate

Main equipment:

ST-01/M (Master) ¹ section	1 (in box #1)
ST-01/S (Slave) ¹ section	1 (in box #2)
Section top cover	2 (in a separate box)



Note:

The type of top cover is to be chosen by the Customer. The following top cover models for the **ST-01** speed gate are available:

- **STC-01G** – is made of tempered glass and features built-in indication block;
- **STC-01S** – is made of stainless steel, features a plastic plate, indication block is not provided;
- **STC-01GS** – is made of tempered glass, features built-in indication block and a central metal plate for installing additional equipment.

Central post indication block	2 (1 in each box #1 and #2)
Swing panel cover plate	4 (2 in each box #1 and #2)
Glass swing panel	2 (in a separate box)



Note:

Swing panels are purchased separately. The type of the swing panel is chosen by the customer. The following swing panel models are available (see Fig. 1 - 5):

- **ATG-300** – for 650 mm passageway arrangement;
- **ATG-300H** – increased height (1300 mm) swing panel for 650 mm passageway arrangement;
- **ATG-425** – for 900 mm passageway arrangement;
- **ATG-425H** – increased height (1500 mm) swing panel for 900 mm passageway arrangement;
- **ATG-475** – for 1000 mm passageway arrangement;
- **ATG-575** – for 1200 mm passageway arrangement.

RC-panel with cable	1 (in box #1)
Jumper	3 (in box #1)
Self-adhesive rubber pad with mnemonic image	2 (in box #1)

Installation tools:

Section top cover mounting kit:

M5×16 bolt	16 (8 in each box #1 and #2)
washer (5)	16 (8 in each box #1 and #2)

Central post indication block mounting kit:

M5×16 bolt	4 (2 in each box #1 and #2)
washer (5)	4 (2 in each box #1 and #2)

Swing panel cover plate mounting kit:

M4×10 screw	8 (4 in each box #1 and #2)
washer (4)	8 (4 in each box #1 and #2)

Swing panel mounting kit:

M10×30 bolt	6 (3 in each box #1 and #2)
M10 nut	6 (3 in each box #1 and #2)
washer (10)	12 (6 in each box #1 and #2)
plastic bushing	6 (3 in each box #1 and #2)

Template for marking on the mounting surface (HDF)	1 (in box #1)
--	---------------

Technical documentation:

Certificate	1 (in box #1)
Assembly and operation manual	1 (in box #1)

Packaging:

Box #1 for ST-01/M section	1
Box #2 for ST-01/S section	1
Box for section top covers	1
Box for swing panels	1

¹ Both sections are delivered with disassembled top covers, panels, panel cover plates and central indication blocks.

4.1.2 STD-01 double-sided section

Main equipment:

Double-sided section ¹	1
Section top cover	1 (in a separate box)



Note:

The type of top cover is to be chosen by the Customer. The following top cover models for the **ST-01** speed gate are available:

- **STC-01G** – is made of tempered glass and features built-in indication block;
- **STC-01S** – is made of stainless steel, features a plastic plate, indication block is not provided;
- **STC-01GS** – is made of tempered glass, features built-in indication block and a central metal plate for installing additional equipment.

Central post indication block	2
Swing panel cover plate	4
Glass swing panel	2 (in a separate box)



Note:

Swing panels are purchased separately. The type of the swing panel is chosen by the customer. The following swing panel models are available (see Fig. 7):

- **ATG-300** – for 650 mm passageway arrangement;
- **ATG-300H** – increased height (1300 mm) swing panel for 650 mm passageway arrangement;
- **ATG-425** – for 900 mm passageway arrangement;
- **ATG-425H** – increased height (1500 mm) swing panel for 900 mm passageway arrangement;
- **ATG-475** – for 1000 mm passageway arrangement;
- **ATG-575** – for 1200 mm passageway arrangement.

RC-panel with cable	1
Jumper	3
Self-adhesive rubber pad with mnemonic image	2

Installation tools:

Section top cover mounting kit:	
M5×16 bolt	8
washer (5)	8
Central post indication block mounting kit:	
M5×16 bolt	4
washer (5)	4
Swing panel cover plate mounting kit:	
M4×10 screw	8
washer (4)	8
Swing panel mounting kit:	
M10×30 bolt	6
M10 nut	6
washer (10)	12
plastic bushing	6

Technical documentation:

Certificate	1
-------------------	---

Packaging:

Box #1 (for double-sided section)	1
Box for section top cover	1
Box for swing panels	1

¹ The section is delivered with disassembled top cover, swing panels, panel cover plates and central indication blocks.

4.2 Optional equipment

The following equipment can be ordered in addition to the standard delivery set:

IR13 or IR19 card readers	2 per a passage lane
FP-01Q.1 front panel with MERTECH N160 P2D barcode scanner	in the required quantity
FP-01C front panel with integrated card reader capture	in the required quantity
FP-01P front panel for installation bracket with additional equipment	in the required quantity
Wireless remote control ¹	in the required quantity
M10 anchor bolts with washers	in the required quantity ²

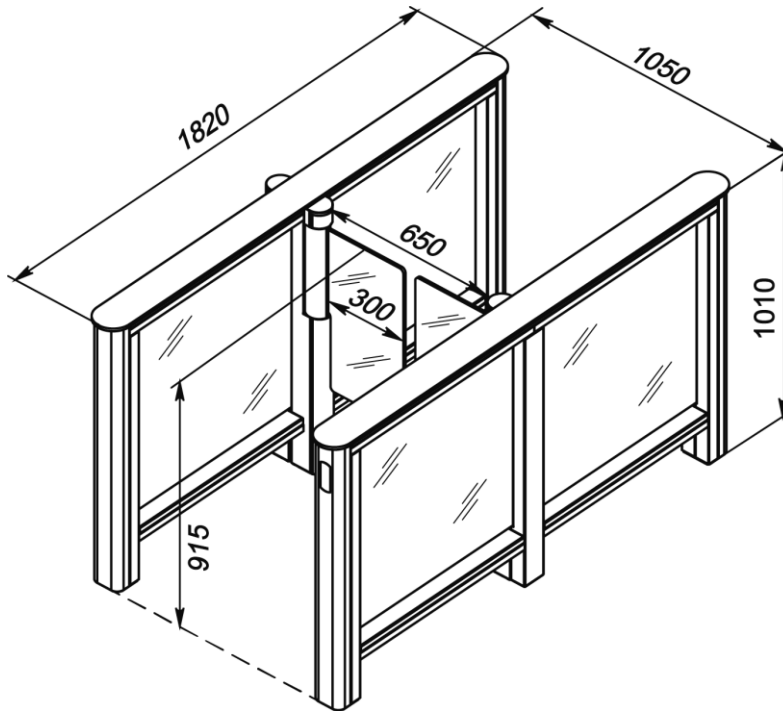

Figure 1. Speed gate overall dimensions with ATG-300 swing panels

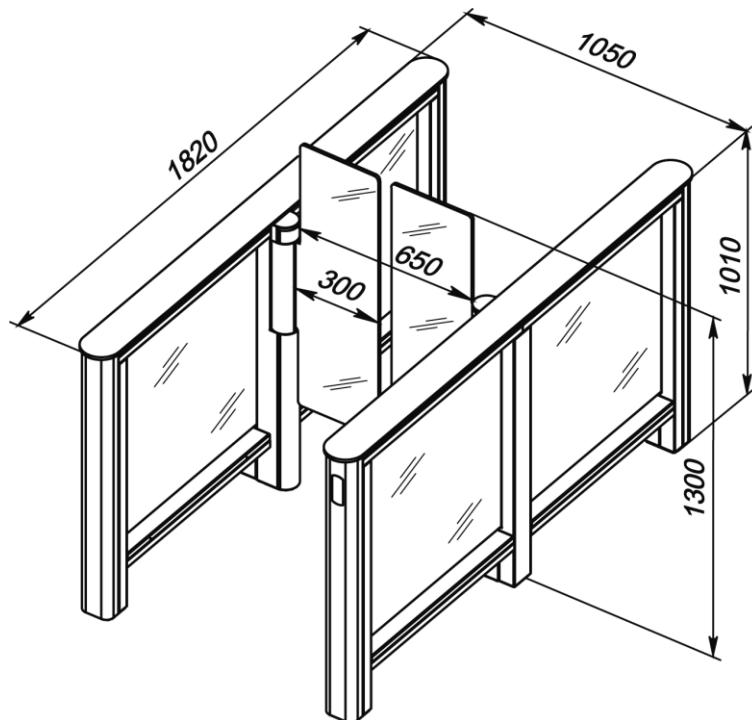

Figure 2. Speed gate overall dimensions with ATG-300H swing panels

¹ The WRC kit consists of a receiver, connected to the control board and a transmitter in the form of a fob.

² To install **PERCo-ST-01**, 22 anchors are required, **PERCo-STD-01** – 14 anchors.

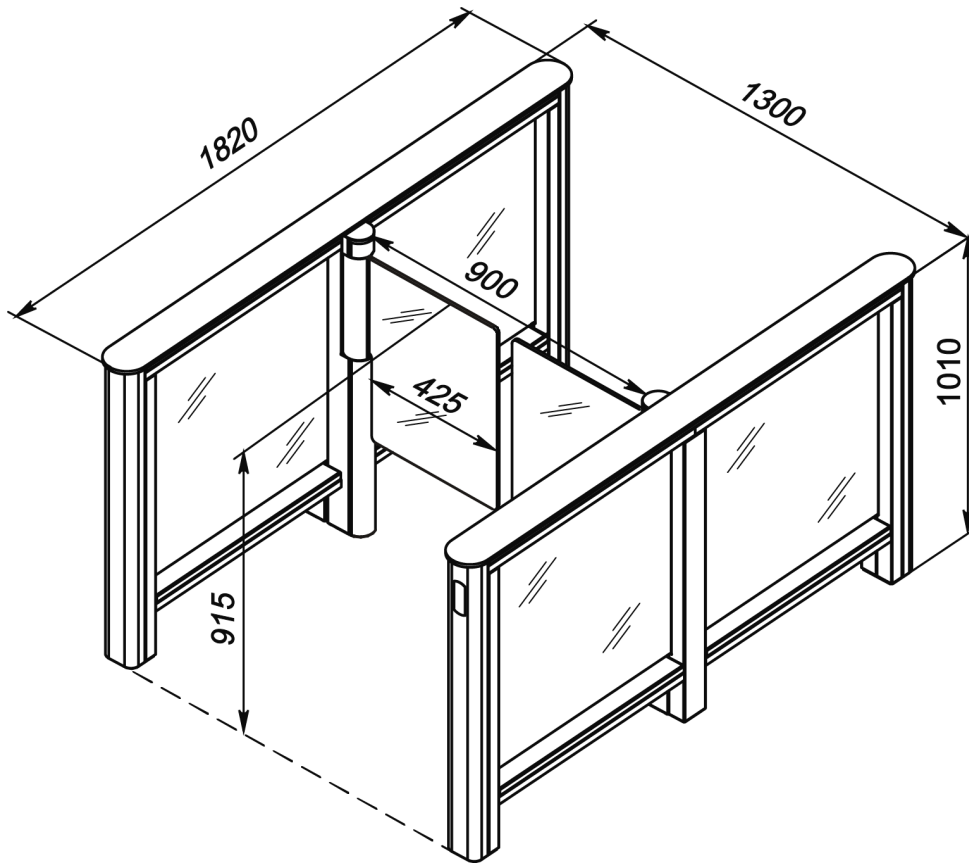

Figure 3. Speed gate overall dimensions with ATG-425 swing panels

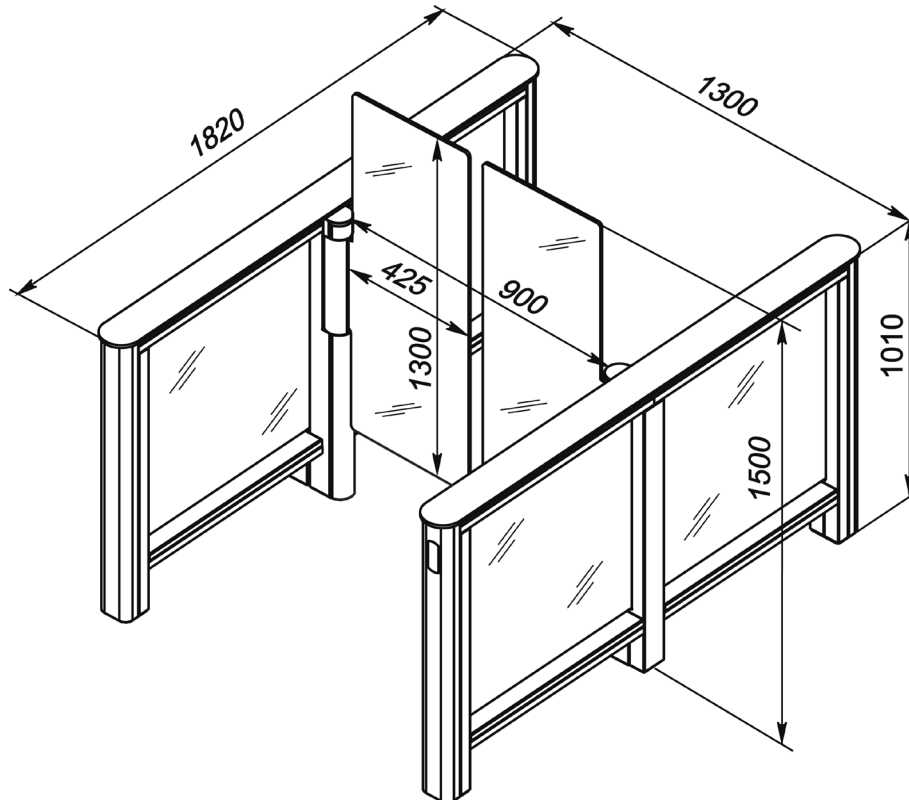

Figure 4. Speed gate overall dimensions with ATG-425H swing panels

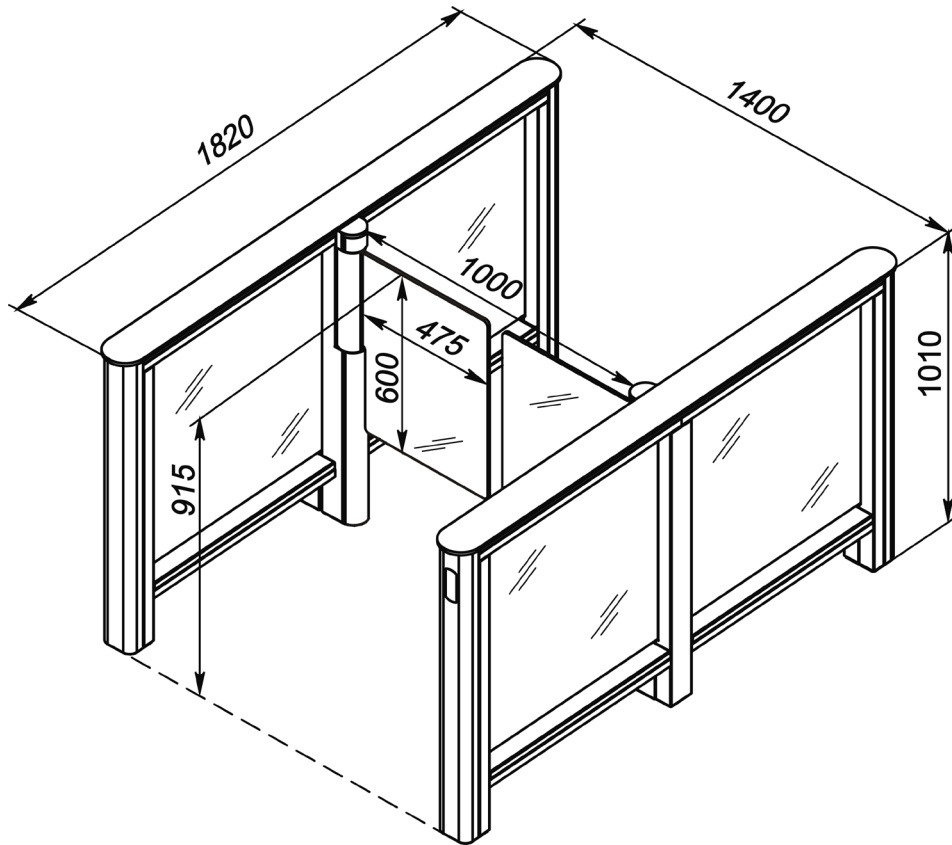

Figure 5. Speed gate overall dimensions with ATG-475 swing panels

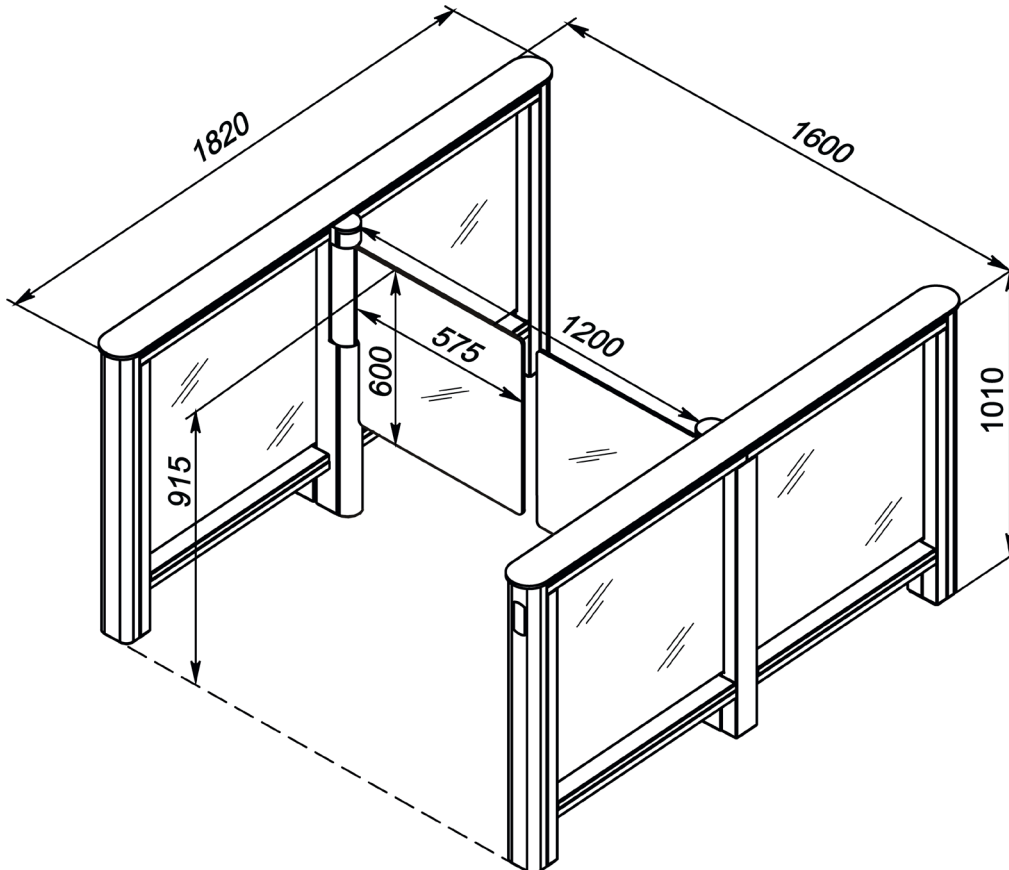

Figure 6. Speed gate overall dimensions with ATG-575 swing panels

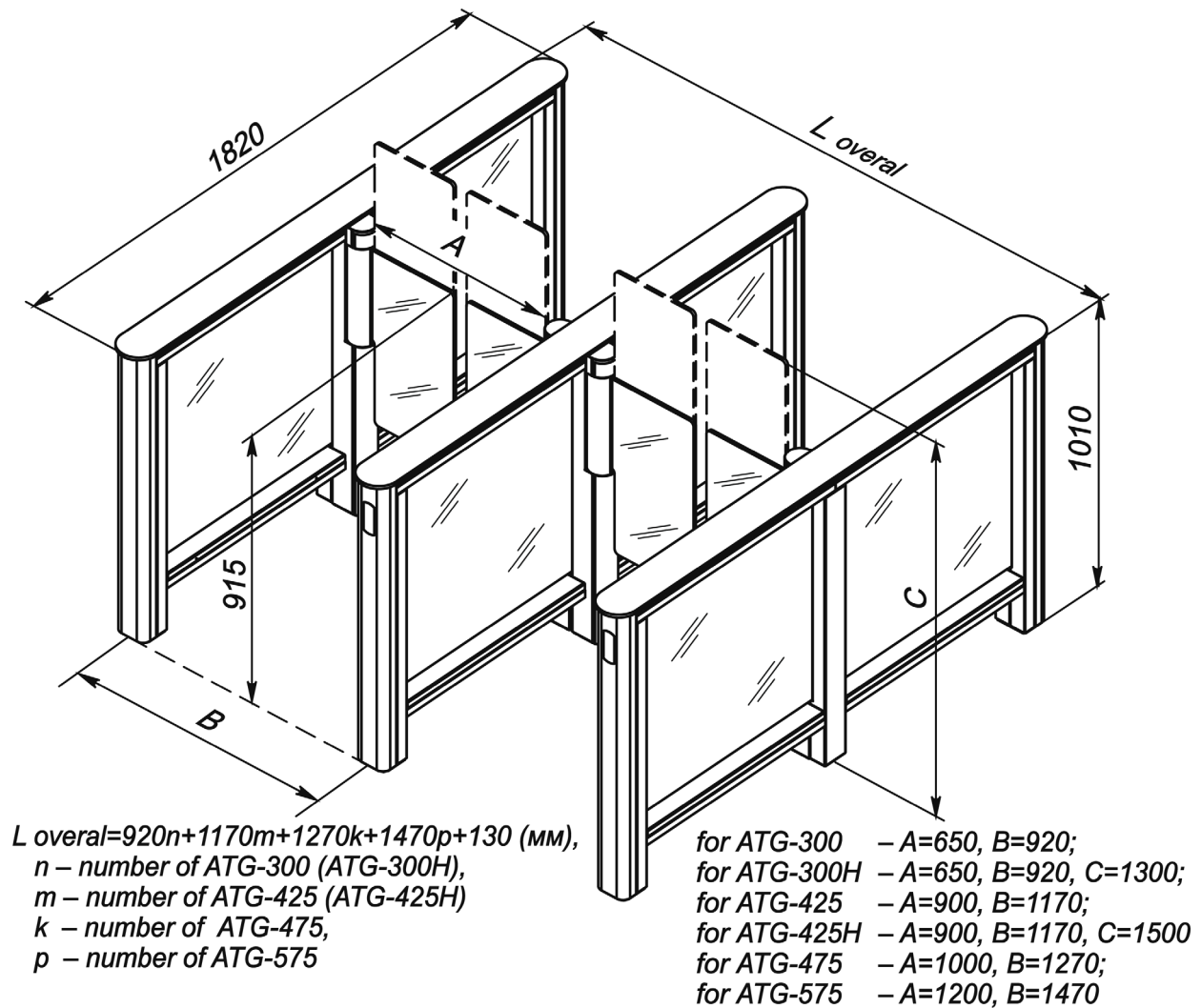

Figure 7. Speed gate overall dimensions with several passage lanes

5 DESIGN AND OPERATION

5.1 Main features

- The speed gate allows to perform several authorized single passages in a row in one direction without the swing panels being closed.
- The speed gate is a normally-open device, which means that when the equipment is de-energized the swing panels move freely at $\pm 90^\circ$ angle.
- The intrusion detectors are installed on two levels throughout the speed gate passage lane. This allows monitoring user's location inside the passage lane. The speed gate also makes it possible for several users to be in the same passage lane at the same time.
- There are several swing panel models, that can be chosen according to the passage lane width and to the operation peculiarities upon making an order.
- Section top covers may be chosen when ordering; they can be made of tempered glass or stainless steel.
- A wide range of optional equipment can be installed: card capture reader, barcode reader, face recognition terminal etc.
- The number of the passage lanes can be increased with **STD-01** double-sided section installation.
- In case several passage lanes are arranged, the front-end indication blocks display the passage direction.
- The speed gate can operate in pulse and potential modes.

- It is possible to switch the speed gate to “*Auto-opening in the selected direction*” mode – entering the speed gate will force the swing panels to automatically open in the preset direction and to close after the passage is finished.
- The speed gate will generate an alarm signal in all operating modes if the passage lane is occupied for more than 30 seconds.
- The equipment can operate as an operating device as a part of ACS or as a standalone unit operated from the RC-panel.
- The speed gate provides the possibility of proximity card readers installation inside the posts under the glass section top cover.
- The glass section top cover (**STC-01G**, **SDC-01G**, **STC-01GS**, **SDC-01GS**) is equipped with indication block (blocks), which features passage granting indicator and proximity card presentation zone indicator.
- The speed gate features the swing panel position adjustment in the initial (locked) position (training mode).
- Indication blocks of the passage grant / denial are located in the user line-of-sight range on the speed gate central section allowing complete the passage as fast as users can walk through the turnstile.
- The equipment provides the possibility of external indication block connection to duplicate passage grant / denial indication.
- Acoustic alarm (siren) connection is provided to warn the operator about unauthorized access attempt.
- Automatic emergency opening of the passage is provided upon receipt of an “*Alarm*” signal. The “*Alarm*” signal can be sent by the emergency system device or by the operator using the emergency button (hereinafter – emergency passage opening device).
- The components are made of polished stainless steel. The swing panels and the filling glass are made of tempered glass of 8 -10 mm thick.

5.2 Design

The speed gate design is shown in Fig. 8; the double-sided section design is shown in Fig. 9. The numbers of the equipment parts are stated in the Manual in accordance with Fig. 8 and 9.

The speed gate consists of two sections, *Master* and *Slave*, and an RC-panel. Each section is equipped with a motorized swing panel (1). *Slave* section is connected to *Master* section with two connection cables (19, 20).

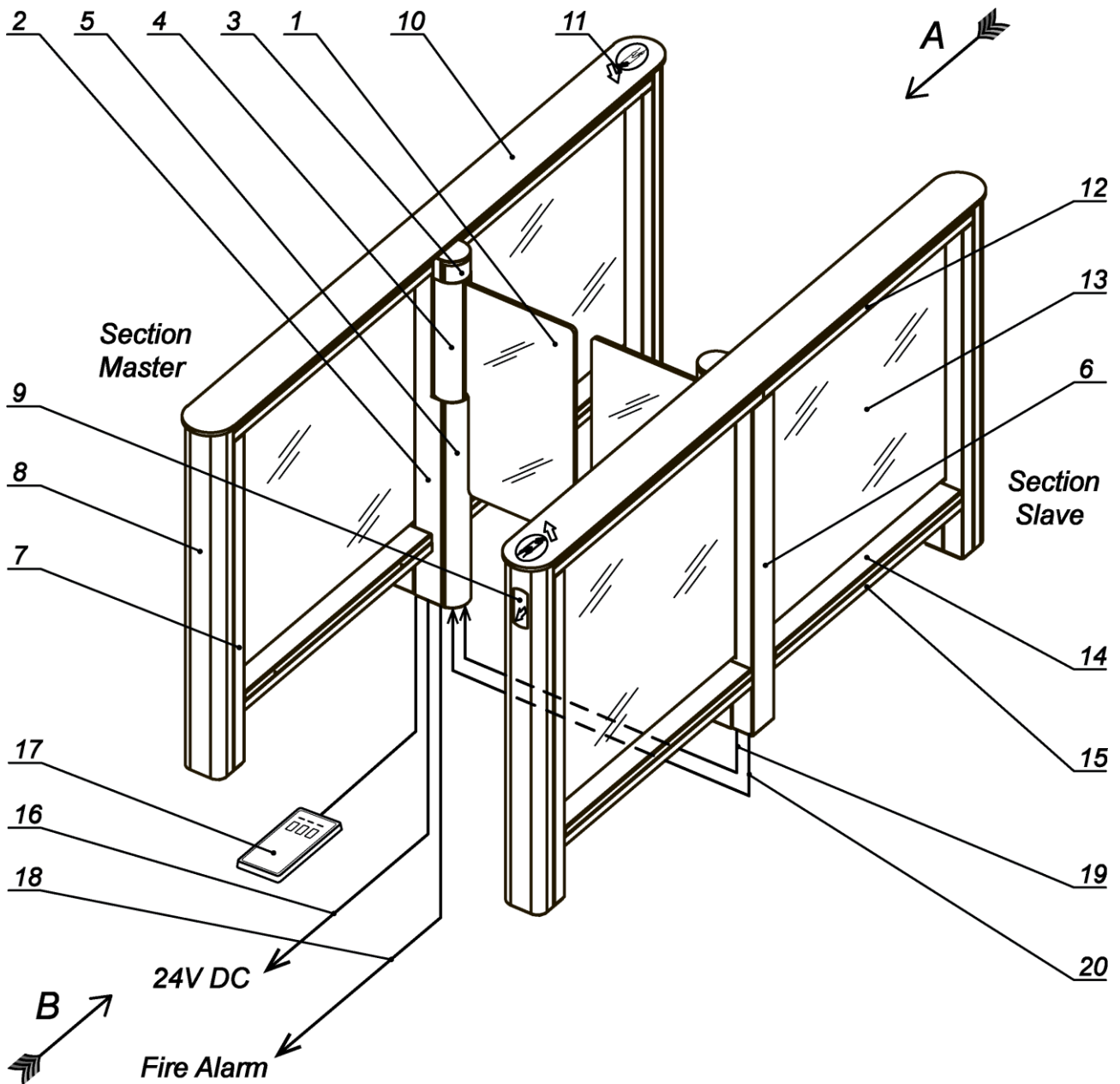

Figure 8. ST-01 overall view:

- 1 – swing panel; 2 – central post; 3 – central post indication block;
 4 – swing panel cover plate; 5 – central post cover plate; 6 – central post rear panel;
 7 – side post; 8 – front panel; 9 – front end indication block;
 10 – section top cover; 11 – top cover indication block; 12 – top duct;
 13 – filling glass; 14 – bottom duct cover; 15 – bottom duct;
 16 – power supply cable¹; 17 – RC-panel with the cable;
 18 – Fire Alarm cable¹; 19 – DC connection cable;
 20 – CAN connection cable.

¹ Not included in the standard delivery set.

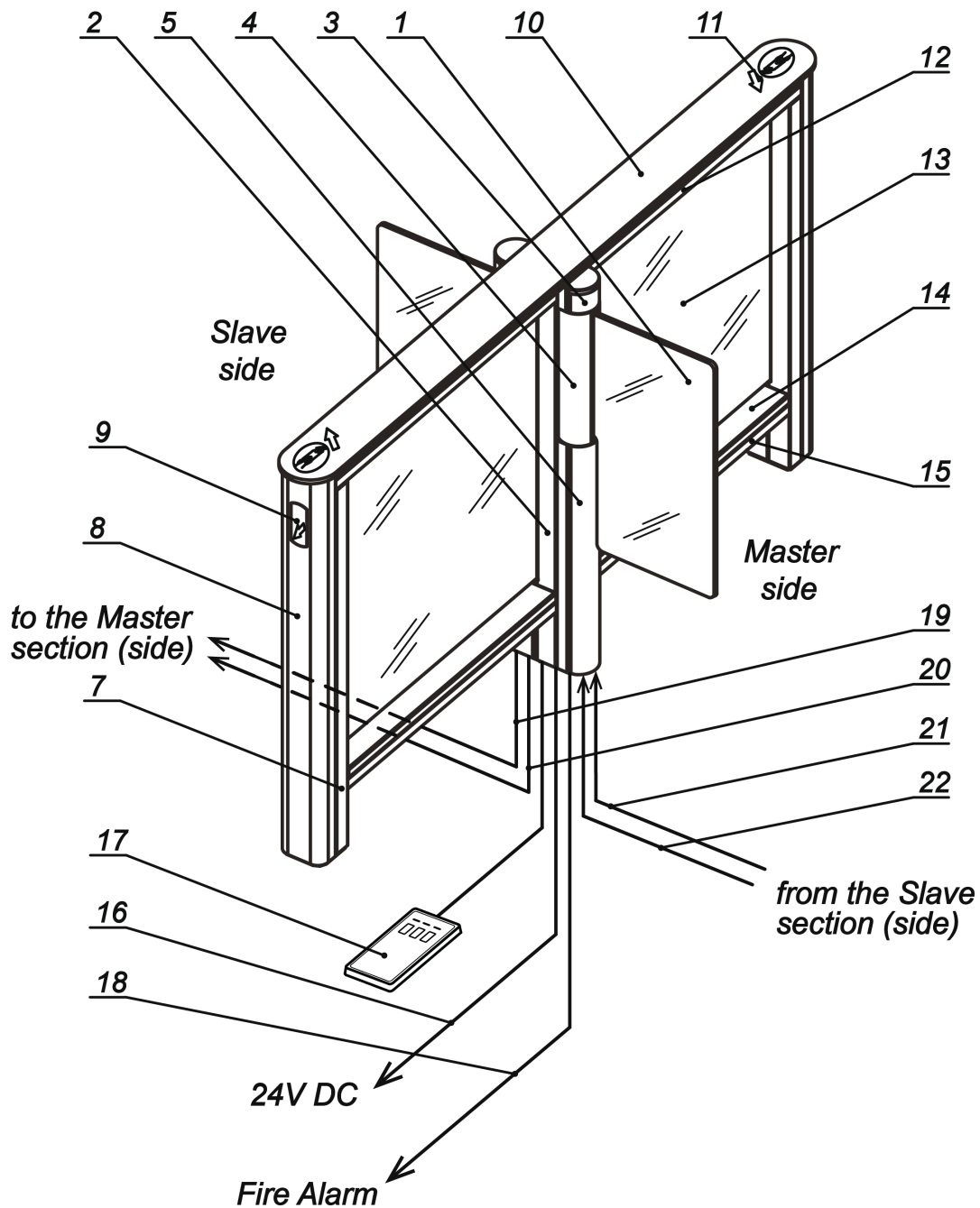

Figure 9. STD-01 overall view:

- 1 – swing panel; 2 – central post; 3 – central post indication block;
- 4 – swing panel cover plate; 5 – central post cover plate; 6 – central post rear panel;
- 7 – side post; 8 – front panel; 9 – front end indication block; 10 – section top cover;
- 11 – top cover indication block; 12 – top duct; 13 – filling glass;
- 14 – bottom duct cover; 15 – bottom duct; 16 – power supply cable¹;
- 17 – RC-panel with cable; 18 – Fire Alarm cable¹;
- 19 – to the *Master* section (side) DC cable;
- 20 – to the *Master* section (side) CAN cable;
- 21 – from the *Slave* section (side) DC cable²;
- 22 – from the *Slave* section (side) CAN cable².

¹ Not included in the standard delivery set.

² From **ST-01** or other **STD-01** delivery set.

Use double-sided sections to arrange more passage lane. The double-sided section is completed with an RC-panel and equipped with two swing panels (1): on the *Master* side and on the *Slave* side. Each swing panel has its motor drive. *Slave* side is connected to the speed gate *Master* section or to the *Master* side of another double-sided section with two connection cables (19, 20). The speed gate *Slave* section (*Slave* side of the next double-sided section) is connected to *Master* side with two connection cables (21, 22) from the standard delivery set.

5.2.1 Section

Each section consists of three posts: one central (2) and two side (7) posts. The posts are interconnected by a top duct (12) and two bottom ducts (15). Each section features a section top cover (10), which covers a top duct. The bottom ducts are covered with bottom duct top covers (14).

The spacing between posts is completed with filling glass (13), which prevents unauthorized entry into the passageway. Bolts, which fasten the filling glasses to the central post, are covered with central post rear panel (6). Bolts, which fasten the filling glasses to the side posts, are covered with the front panels (8).

The section top cover is equipped with an indication block (blocks) (11), which features a passage granting indicator (green arrow) and a card presentation zone indicator (“a hand with a card” pictogram).

The side posts are equipped with the front-end indication blocks (9) indicating the passage direction or passage denial (white arrow or red cross).

The central post (2) features an indication block (3) with square color indicators of passage grant / denial.

The swing panel (1) is fixed to the central post rotating support. The rotating support is covered with the central post cover plate (5). The rotating support is driven by motor, located under the swing panel cover plate (4).

The glass section top cover (**STC-01G**, **SDC-01G**, **STC-01GS**, **SDC-01GS**) features an indication block (blocks) (11), that consists of passage granting indicator (green arrow) and access card presentation zone indicator (“hand with a card” pictogram).

The bottom part of the *Master* section central post features **ST-01.771** speed gate control board (hereinafter – *control board*). The PS, the RC-panel (WRC receiver), Fire Alarm device and *Slave* section connection cables are connected to the control board.

5.2.2 Indication blocks

Each section features the following indication blocks:

- Top cover (**STC-01G**, **SDC-01G**, **STC-01GS**, **SDC-01GS**) indication block (11) includes a white indicator (a hand with a card), indicating the card presentation zone and a green indicator (an arrow), which lights up in case the passage in this direction is granted:



- green indicator of passage granting
- white indicator of card presentation zone

- Central post indication block (3) is designed for passage grant (green light) / denial (red light) indication for each direction.
- Front end indication block (9) is designed for indicating passage direction through the speed gate. It displays the constant indication (white arrow or red cross):

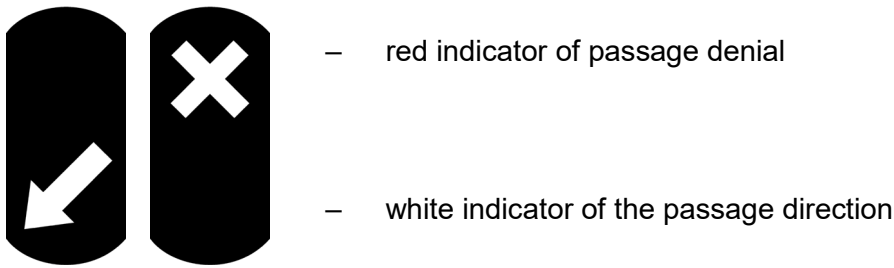

The type of indication of the front-end block can be chosen during the installation of the speed gate by connecting the front-end cable to the corresponding indication control module connector (located under the speed gate cover on the protection plate, Fig. 22). By default, the cable is connected to the **ARROW** connector, the area where white arrow points at. To access the speed gate indication control module, the section top cover is to be removed (10) (see Sect. 8.9.6).

5.2.3 RC-panel

RC-panel (17) is a small table device made of shockproof ABS plastic. RC-panel is designed for speed gate operation in the manual mode, in which the operator sends commands to the equipment. The overall view of the RC-panel is shown in Fig. 10.

RC-panel housing features three control buttons for sending commands. The middle **STOP** button serves for setting the “Always locked” mode. The **LEFT** and **RIGHT** buttons serve to open the passage in the chosen direction. Up above the buttons there are LED lights, indicating passage direction status. The red “Stop” indicator shows the “Always locked” operating mode. The possible operation commands and RC-panel indication for pulse and potential operating modes are stated in Tables 7 and 8.

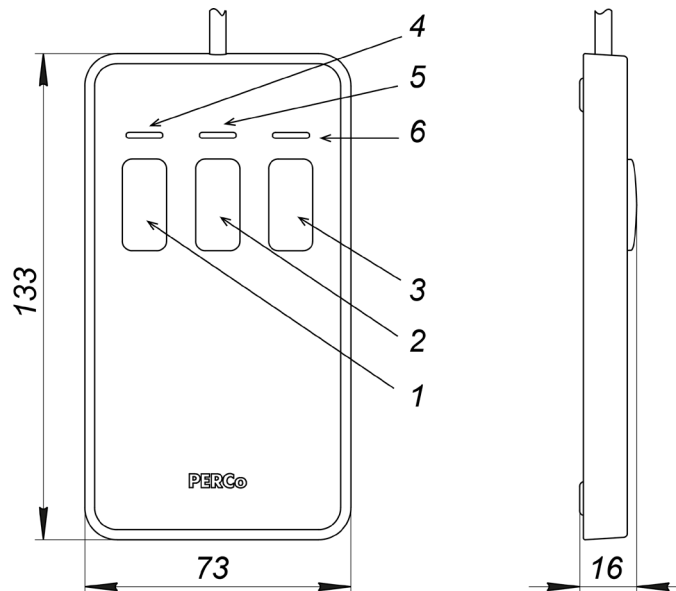

Figure 10. Overall view and dimensions of the RC-panel

1, 2, 3 – **LEFT, STOP, RIGHT** buttons for mode setting;
 4, 6 – green “Left”, “Right” indicators; 5 – red “Stop” indicator

5.2.4 Control board

Speed gate control board (Fig. 11) is installed in the central post of *Master* section. Remove the central post cover plate in order to access the board (see Sect. 8.9.1).

The control board features a microcontroller, which processes the incoming control commands, transferred to *Unlock A, Stop, Unlock B* and *Fire Alarm* control inputs, monitors the status of swing panels turn optical sensors and creates commands for the motor drive of the speed gate swing panels on the basis of the data received.

The microcontroller also creates signals on the control board outputs: for indication on the RC-panel (*Led A*, *Led Stop* and *Led B* outputs), for the external indication (*Light A*, *Light B* outputs), about the passage registration in the corresponding direction (*PASS A* and *PASS B*), about the alarm (*Alarm*). The control board features:

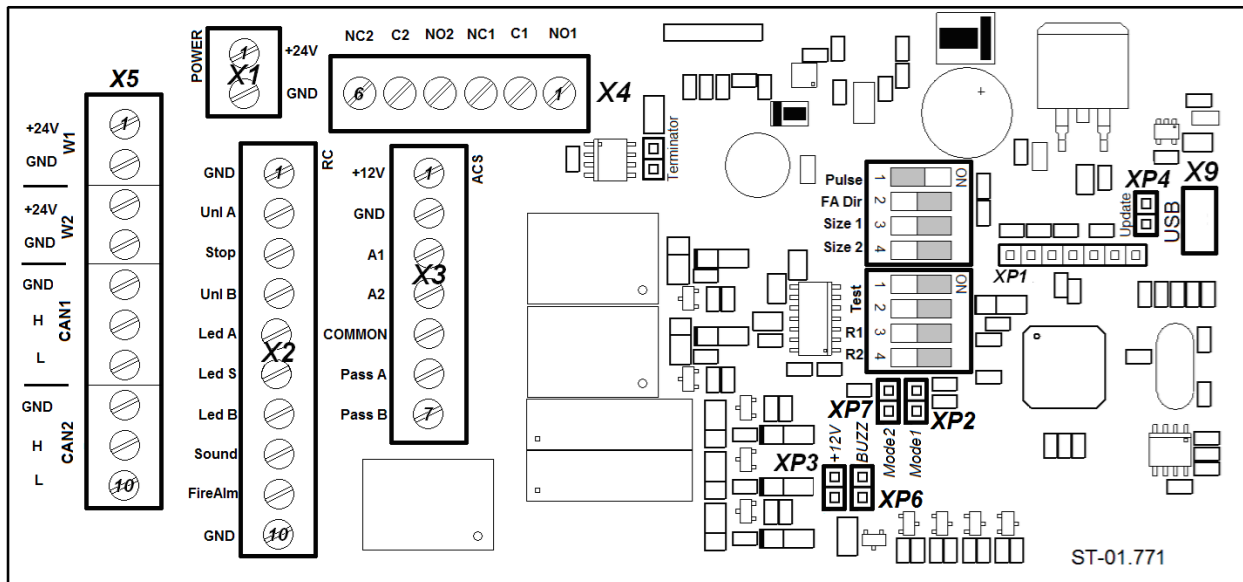

Figure 11. Control board overall view

Connector blocks to connect:

- **X1 (Power)** – speed gate power supply.
- **X2 (RC)** – operating devices: RC-panel, wireless remote control, control outputs of the ACS-controller, Fire Alarm device.
- **X3 (ACS)** – sirens and ACS-controller inputs to the control board outputs.
- **X4** – remote indication blocks to the controller board relay outputs.
- **X5** – DC and CAN connection cables of swing panel motor drives.
- **X9** – *mini-USB* connector for speed gate built-in software update.

Connectors for jumper installation:

- **XP1 (Program)** – secondary connector.
- **XP2 (Mode 1)** – connector not used (jumper is not installed upon delivery).
- **XP3 (+12V)** – connector for turning on LED indication on the control board.
- **XP4 (Update)** – connector for switching the control board to a Software update mode through USB interface. The jumper is removed by default.
- **XP6 (BUZZ)** – connector for turning on the buzzer on the control board. Buzzer operation duplicates operation unit sound indication and siren activation. The jumper is installed by default, which corresponds to the activated buzzer.
- **XP7 (Mode2)** – connector for selecting the control mode when passing through the turnstile - normal or enhanced. Upon delivery, the jumper is removed, which corresponds to the enhanced control mode - in this mode, the “safe” zone is limited by the width of the turnstile swing panels. In normal control mode (the jumper is installed), the “safe” zone is the entire space between the turnstile sections.

Switches:

- **Pulse** – to turn the speed gate to a pulse control mode. By default, the switch is in **ON** position, which corresponds to a pulse speed gate operating mode.
- **FA_Dir** – to choose swing panel direction of rotation in case an emergency passage opening (*Fire Alarm*) signal is sent. By default, the switch is in **OFF** position, which corresponds to the swing gate being opened in B direction.
- **Size1, Size2** – to set the speed gate swing panels size. By default, both switches are in **OFF** position.

Table 1. Positioning of Size1, Size2 switches according to the swing panel type

Swing panel model	Switches positioning	
	Size1	Size2
<i>ATG-300</i>	ON	OFF
<i>ATG-300H</i>	ON	ON
<i>ATG-425, ATG-475</i>	OFF	OFF
<i>ATG-575, ATG-425H</i>	OFF	ON

- **Test1** – not used. When operating, the switch must be in OFF position.
- **Test2** – for turning on LED indication on intrusion detectors boards. By default, both switches are in **OFF** position, which corresponds to the indication being switched off.
- **R1** – turns on the “*Auto-opening in the selected direction*” mode (Sect. 8.8). By default, the switch is turned **OFF** (see Table 2).
- **R2** – switches the speed gate to the training mode (Sect. 8.7), if the **R1** switch is in **OFF** position, or is used for selecting the direction of “*Auto-opening*” mode if the **R1** switch is in **ON** position. By default, the switch is set in **OFF** position (see Table 2).

Table 2. Speed gate operating modes in different positions of R1 and R2 switches

Switch position		Mode
<i>R1</i>	<i>R2</i>	
OFF	OFF	Training and “ <i>Auto-opening</i> ” modes are turned on
OFF	ON	Training mode is switched on (Sect. 8.7)
ON	OFF	“ <i>Auto-opening</i> ” mode is switched on in A direction (Sect. 8.8)
ON	ON	“ <i>Auto-opening</i> ” mode is switched on in B direction (Sect. 8.8)

Table 3. Function of the control board terminal block contacts

Connector block	№	Contact	Function
X1 (Power)	1	+24V	External power supply connection
	2	GND	
X2 (RC)	1	GND	General
	2	Unlock A	A direction control input
	3	Stop	Passage denial control Input
	4	Unlock B	B direction control input
	5	Led A	A direction control input on the RC-panel
	6	Led Stop	Passage denial control input on the RC-panel
	7	Led B	B direction control input on the RC-panel
	8	Sound	RC-panel sound signal output
	9	Fire Alarm	Emergency passage unlocking control input
	10	GND	
X3 (ACS)	1	+12V	+12V output for additional equipment powering
	2	GND	General
	3	Alarm1	Siren connection output
	4	Alarm2	
	5	Common	Common for <i>PASS A</i> , <i>PASS B</i> outputs
	6	PASS A	<i>PASS A</i> relay contact (passage in A direction)
	7	PASS B	<i>PASS B</i> relay contact (passage in B direction)
X4	1	NO1	Normally open contact of the <i>Light A</i> output
	2	C1	Common contact of the <i>Light A</i> output
	3	NC	Normally closed contact of the <i>Light A</i> output
	4	NO2	Normally open contact of the <i>Light B</i> output
	5	C2	Common contact of the <i>Light B</i> output

5.2.5 Control signals

Speed gate operation is performed by sending control signals to *Unlock A*, *Stop* and *Unlock B* outputs. The control signal is **sending a low-level signal** to *Unlock A*, *Stop* and *Unlock B* contacts regarding *GND* contacts. Normally open relay contact or layout with an open collector output can serve as a control element (Fig. 12 and 13).

Speed gate emergency unlocking is performed by sending a control signal to *Fire Alarm* input. The control signal is a **low-level signal release** from *Fire Alarm* contact regarding *GND* contact. A normally closed relay contact or an open collector output layout can serve as a control element. In this case all other incoming control commands are ignored. Sending a low-level signal to *Fire Alarm* input, “Always locked” mode is activated, in which the swing panels get closed (Sect. 5.3.2).



Note:

Use 1 kOhm resistors connected to + 3,3 V voltage plane to generate a high-level signal on all input contacts (*Unlock A*, *Stop*, *Unlock B*, *Fire Alarm*).

Control element is to provide the following characteristics of the signals:

control element – relay contact:

minimum commutated current max 4 mA

closed contact resistance

(regarding connection cable resistance) max 200 Ohm

control element – open collector output layout:

closed contact voltage (low level signal, on the control board input) max 0.8 V

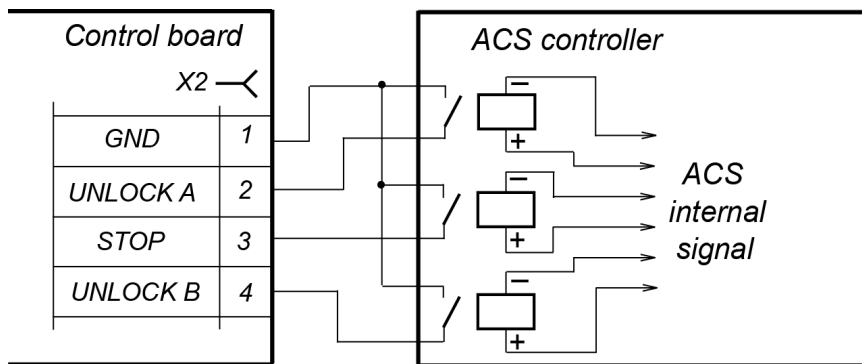

Figure 12. Control elements of the external device – normally open relay contact

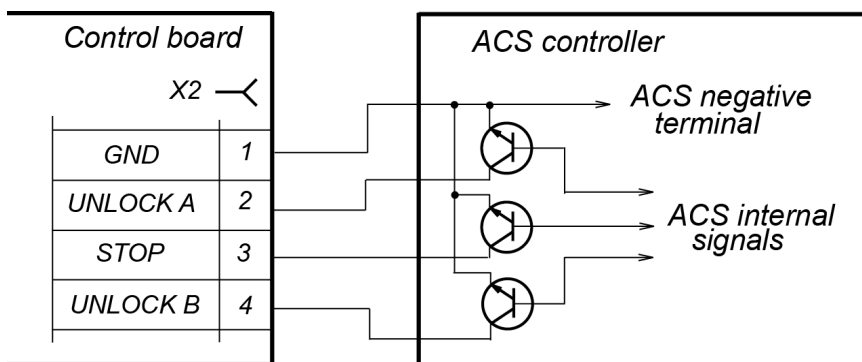

Figure 13. Control elements of the external device – open collector output layout

5.2.6 Control modes

There are two speed gate control modes – pulse and potential. In both modes the speed gate is controlled by sending commands (i.e. control signals combinations) to *Unlock A*, *Stop* and *Unlock B* control inputs and to a special *Fire Alarm* control input. Control command sending algorithm changes depending on the chosen mode.



Attention!

Change the switch positioning, remove and install jumpers on speed gate boards with de-energized equipment.

The control mode is chosen by **Pulse** switch on the speed gate control board (Fig. 11). Upon delivery the switch is in **ON** position, which corresponds to pulse speed gate mode.

Shift the switch into **OFF** position to place the speed gate into potential control mode. Control mode will be changed after speed gate being powered.

Pulse control mode

The mode is used for speed gate operation from RC-panel, wireless remote control and ACS-controller with the outputs supporting pulse control mode. Speed gate operation at pulse control mode is described in Table 7.

Control signal duration at sending control command to control inputs is to be not less than 100 ms. The initial passage waiting time is 8 seconds and it is independent of control signal (pulse) duration.

Control command sending algorithm, which is a combination of control signals, is given in Appendix 1. A control command is an active front of the control signal (signal shifting from high level to a low level) at any of the control inputs (*Unlock A*, *Unlock B* and *Stop*), in case there are corresponding signal levels at other inputs.



Note:

Push the corresponding button on RC-panel to send control signals from the RC-panel / WRC to the signal active front. Pressing the button corresponds to the low level of the signal; non-pressing the button corresponds to the high level of the signal.

Potential control mode

The mode is used for speed gate operation with ACS-controller. The outputs of the ACS-controller are to support potential control mode. Speed gate operation in potential control mode is described in Table 8.

Control signal duration at sending control command to control inputs is to be not less than 100 ms. The passage waiting time is equal to control signal duration, i.e. that if by the moment of passage completion in the permitted direction, there is a low-level signal at the input of this direction, the speed gate remains open in this direction.

Control command sending algorithm is given in Appendix 2. Sending a low-level signal to *Stop* input, both directions are locked for signal duration time independently of signal levels at *Unlock A* and *Unlock B* inputs. Removing low-level signal from *Stop* input, the directions shift into the modes, according to signal levels at *Unlock A* and *Unlock B* inputs.



Note:

When the speed gate is operated from the ACS, high level of the control signal corresponds to the open contacts of the controller output relay or to the closed output transistor. Low level of the control signal corresponds to the closed contact of the controller output relay or to the open output transistor.

5.2.7 Speed gate operation algorithm

Speed gate operation algorithm in pulse control mode in case of single passage in one of the directions:

1. A command (control signals combination) for single passage performance in one of the directions is sent from the control device (RC-panel, WRC, ACS-controller) to the control board inputs.
2. The microcontroller on the control board processes the received combination of signals and creates a command for the swing panels motor drive to open the passage. The **Time of holding in unlocked state** (8 seconds by default) countdown begins.
3. The speed gate swing panels open in the chosen direction. The user can pass through the speed gate in the chosen direction.
4. Any movement detected in the passageway is registered as a completed passage. *PASS A* or *PASS B* relay output, corresponding to the passage direction, is activated for 80 ms. User's location in the passageway is monitored by the intrusion detectors.

**Note:**

In order to prevent user contact with the turnstile doors, a “safe” zone is allocated inside the passage area. When the user is in this area, the movement of the swing panels (opening or closing) is blocked. In the normal control mode (**MODE2** jumper is installed), the entire passage area of the **PERCo-ST-01** turnstile is covered; in the enhanced control mode (**MODE2** jumper is removed, by default), the “safe” zone is limited by the width of the installed swing panels.

5. After the user passes through the open swing panels he gets into a safe zone (zone, in which it is impossible to get in contact with the swing panels) and the control board microcontroller sends a command for the motor drive to close the swing panels. The swing panels get closed.
6. If at the moment of passage performance by the first user, another user’s passage has been authorized **in the same passage direction**, the swing panels will not get closed and the new user will be able to follow the first one.
7. If at the moment of passage performance, another user’s passage has been authorized **in the opposite passage direction**, then after the first user’s passage completion the swing panels will be closed and open in the opposite direction for the second user to pass.

**Note:**

In order to increase throughput rate, arrangement of separate passage lanes for each direction is recommended. Passage directions for each passage lane can be displayed on the front-end indication blocks.

8. If the user does not enter the passageway during the **Time of holding in unlocked state**, the swing panels will close the passage lane.
9. After the passage is completed and the swing panels are closed, the speed gate is ready for another passage.

In potential speed gate control mode, the control signal can be released after receiving a signal from *PASS* output for the same direction.

5.3 Operating devices

Speed gate operation can be performed through the following devices: RC-panel / WRC; ACS-controller, Fire Alarm device. These devices can be connected to the speed gate separately, simultaneously or in any combination with each other.

In case several operating devices are connected simultaneously there can be a control signal overlap. In this case speed gate will operate according to the command, generated by the signal combination (Appendixes 1 and 2).

5.3.1 RC-panel connection

RC-panel is connected with a flexible multicore cable to *Unlock A*, *Stop*, *Unlock B*, *Led A*, *Led Stop*, *Led B*, *Sound* and *GND* contacts of the **X2** terminal block according to the speed gate connection layout (Fig. 20).

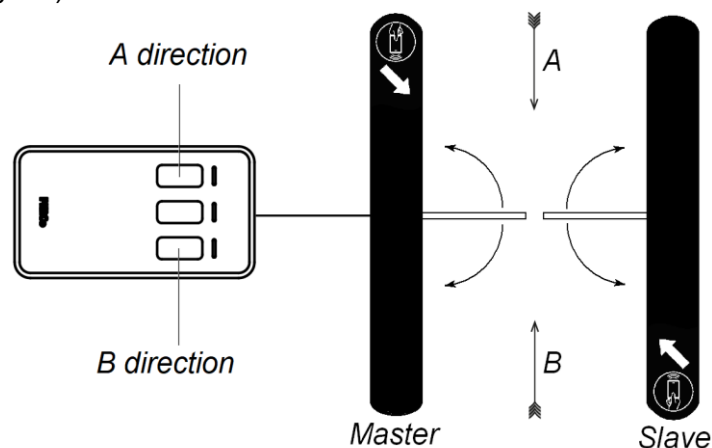

Figure 14. Standard RC-panel orientation regarding speed gate sections



Note:

WRC is connected to *Unlock A*, *Stop*, *Unlock B* and *GND* contacts of the **X2** terminal block. Power supply of the WRC is connected to +12V contact of the **X3** terminal block.

Standard RC-panel orientation regarding sections is stated in Fig. 14. If the operator’s workspace is located on the opposite side regarding *Master* section, it will be more convenient to change the RC-panel wires, which are connected to *Unlock A* and *Unlock B* contacts, as well as *Led A* and *Led B* respectively (Table 4).

Table 4. Connection of RC-panel cable wires to the X2 connector block

№	Contact	RC-panel orientation	
		Standard	Reverse
1	<i>GND</i>	black	black
2	<i>Unlock A</i>	white	green
3	<i>Stop</i>	blue	blue
4	<i>Unlock B</i>	green	white
5	<i>Led A</i>	yellow	red
6	<i>Led Stop</i>	orange	orange
7	<i>Led B</i>	red	yellow
8	<i>Sound</i>	brown	brown

5.3.2 Fire Alarm device

Connect the Fire Alarm emergency passage unlocking device to control board *Fire Alarm* input (*Fire Alarm* and *GND* contacts of the **X2** terminal block) according to the speed gate connection layout (Fig. 20).

If the *Fire Alarm* input is not used, a jumper between *Fire Alarm* and *GND* contacts of the control board is to be installed. This jumper is installed by default.

When a control signal is applied to the *Fire Alarm* input and held for at least 2 sec¹, the turnstile switches to *Fire Alarm* mode. In this mode the following operations take place:

- Speed gate swing panel open in the direction, chosen with **FA_Dir** switch (Fig. 11).
- Green passage permission indicators of the top cover and the central post indication blocks switch on to the flashing mode with a period of 1.25 sec simultaneously for both directions.
- All the incoming speed gate control commands are ignored.

After the *Fire Alarm* signal is removed, the swing panels of the turnstile will be open for another 3 sec, after which the swing panels will close and the turnstile will return to normal operation.

If a control signal is received at the *Fire Alarm* input during a passage, the swing panels remain open in this direction until the signal is removed.

5.3.3 Operation from the ACS

Operating as a part of the ACS, the speed gate can serve as an operating device. Speed gate also provides an opportunity of built-in proximity card readers installation under the section top cover.

ACS-controller outputs are connected to *Unlock A*, *Stop*, *Unlock B* and *GND* contacts of the **X2** terminal block. ACS-controller inputs are connected to *PASS A*, *PASS B* and to *Common* contacts of the **X3** terminal block. Connection is performed in accordance with the speed gate connection layout (Fig. 20).

5.4 Optional devices connected to the speed gate

The speed gate control board features the following outputs for optional devices connection:

- *PASS A*, *PASS B* – for connection to ACS-controller inputs (Sect. 5.4.1).
- *ALARM* – for siren connection (Sect. 5.4.2).
- *Light A* and *Light B* – for external indication blocks connection (Sect. 5.4.3).

¹ If the duration of the Fire Alarm signal is less than 2 seconds, the turnstile will not switch to Fire Alarm mode and will remain in normal operation mode.

5.4.1 PASS outputs

Connection to *PASS A*, *PASS B* relay outputs is performed through *Pass A*, *Pass B*, *Common* contacts of the **X3** terminal block on control board in accordance with the speed gate connection layout (Fig. 20).

Relays have normally open contacts. The *Common* relay contact is not connected to the speed gate power supply return. Normalized voltage is not supplied to relay winding.

Outputs are activated at passage registration through speed gate in a corresponding direction. During the activation process, voltage is supplied on relay winding and relay contacts get closed. Voltage supply to relay winding is indicated by the red LED light on the control board by the corresponding relay (if the jumper on the control board is installed on **XP3 (+12V)** output).

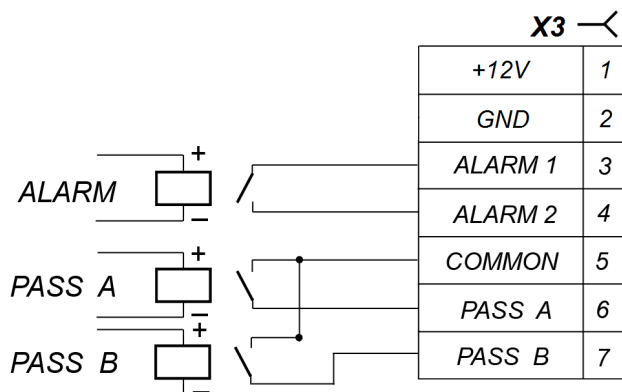

Figure 15. PASS A, PASS B and Alarm pass elements

Pass elements – relay contacts (Fig. 15) with the following signal characteristics:

maximum commutation DC voltage	42 V
maximum commutation current.....	0.25 A
closed contact resistance	max 0.15 Ohm

5.4.2 Siren

Siren is connected to *ALARM* relay output on the control board through *Alarm 1*, *Alarm 2*, *GND* and *+12V* contacts of the **X3** terminal block in accordance with the speed gate connection layout (Fig. 20).

Normalized voltage is not supplied on relay winding and the relay contacts are open. Output is activated when intrusion detectors register an unauthorized passage. During the activation process, voltage is supplied on relay winding and relay contacts get closed. Voltage supply to relay winding is indicated by the red LED light on the control board by the corresponding relay (if the jumper on the control board is installed on **XP3 (+12V)** output).

Pass elements – relay contacts (Fig. 15) with the following signal characteristics:

maximum commutation DC voltage	42 V
maximum commutation current	0.25 A
closed contact resistance	max 0.15 Ohm

Maximum consumption current of the siren, connected to the contact *+12V* of the **X3** connector block on control board should not exceed 0.3 A.

5.4.3 External indication

External indication blocks for corresponding passage directions are connected to *Light A* and *Light B* outputs. Outputs have the full contact block: *NO* normally open, *NC* normally closed and *C* common contacts. Connection to the outputs is performed through the corresponding contacts of the **X4** terminal block.

With passage grant indication in A/B direction the relay of the corresponding *Light A / Light B* passage direction is activated (voltage is supplied to its winding) and normalized at passage denial indication. Power supply to relay winding can be indicated by the red LED light on the control board by the corresponding relay. Pass elements for *Light A* and *Light B* – relay transfer contacts (Fig. 16) with the following signal characteristics:

maximum commutation DC voltage	30 V
maximum commutation AC voltage	42 V
maximum commutation AC/DC current	3 A
closed contact resistance	max 0.15 Ohm

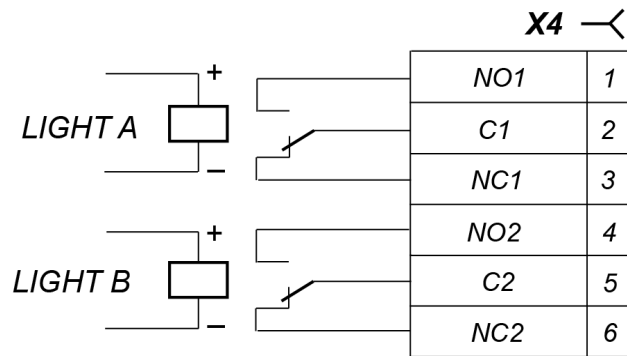

Figure 16. Light A and Light B pass elements

6 MARKING AND PACKAGING

Each speed gate section has a marking label that can be found inside the section top duct. To access the marking label, open the section top cover (Sect. 8.9.6). The label contains trademark and contact details of the manufacturer, section name and product serial number, date of manufacture, power supply voltage and speed gate power input.

Speed gate *Master* section and double-sided section also have the label on the internal surface of the central post cover plate (5). Remove the post cover plate to access the label (Fig. 21). The label contains speed gate connection layout similar to the one shown in Fig. 20.

Speed gate in a standard delivery set is packed in transportation boxes, protecting it from being damaged during transportation and storage. The number of boxes depends on the ordered delivery set.

Transportation boxes dimensions (length × width × height):

ST-01:

Box #1 (ST-01/M section)	196×36×111 cm
Box #2 (ST-01/S section)	196×36×111 cm

STD-01:

Box #1 (double-sided section)	196×36×111 cm
Box with STC-01, SDC-01 (set of section top covers)	197×14×24 cm
Box with ATG-300 (set of swing panels)	66×44×8 cm
Box with ATG-300H (set of swing panels)	104×44×8 cm
Box with ATG-425 (set of swing panels)	66×56×8 cm
Box with ATG-425H (set of swing panels)	136×56×8 cm
Box with ATG-475 (set of swing panels)	66×61×8 cm
Box with ATG-575 (set of swing panels)	66×71×8 cm

Transportation boxes weight (gross):

ST-01:

Box #1 (ST-01/M section)	max 130 kg
Box #2 (ST-01/S section)	max 125 kg

STD-01:

Box #1 (double-sided section)	max 145 kg
Box with STC-01 (set of section top covers)	max 24 kg
Box with SDC-01 (double-sided section cover)	max 18 kg
Box with ATG-300 (set of swing panels)	max 16 kg
Box with ATG-300H (set of swing panels)	max 21 kg
Box with ATG-425 (set of swing panels)	max 19 kg
Box with ATG-425H (set of swing panels)	max 43 kg
Box with ATG-475 (set of swing panels)	max 23 kg
Box with ATG-575 (set of swing panels)	max 27 kg

7 SAFETY REQUIREMENTS

7.1 Installation safety requirements

Speed gate installation is to be performed by qualified personnel after careful study of this Manual with observance of general safety rules.



Attention!

- All works should be performed only after the power supply is switched off and disconnected from the AC mains.
- Only serviceable tools should be used for installation.
- Sections unpacking and relocation, section top cover and swing panels installation are to be carried by at least two professionals.
- Wearing protection gloves is obligatory! Housing details made of stainless steel may contain sharp edges.
- During the installation, before the sections are fixed to the floor, prevent them from falling down.
- Before the first speed gate power-up, make sure installation and all connections are done properly.

Power supply installation should be performed with observance of safety rules, given in its operation manual.

7.2 Operation safety requirements

Observe general electrical safety rules when operating the speed gate.



Attention!

- Do not use the speed gate in conditions that do not comply with the requirements given in Sect. 2.
- Do not use the speed gate at supply voltage that does not comply with the requirements given in Sect. 3.

Power supply unit must be operated with observance of safety requirements mentioned in its operational documentation.

8 INSTALLATION

Speed gate installation should be performed with observance of safety rules described in Sect. 7.1.

Speed gate installation should be carried out by, at least, two qualified professionals who have accurately studied the following manual. Carefully study this section before the installation and follow it thereafter.



Attention!

The manufacturer shall not be liable for any damage caused by the improper installation and declines any claims arising thereof in case the installation is not done in compliance with the instructions provided in this Manual.

8.1 Installation details

It is recommended:

- to mount the speed gate on a steady and level concrete (grade 400 or higher, strength class B22.5), stone or similar foundation at least 150 mm thick.
- to level the foundation so that the anchoring points of the speed gate are flush with the surface (check it with a level).
- to apply reinforcing elements (450×450×200 mm) in case the speed gate is to be installed on a less steady foundation.



Attention!

During speed gate section installation leave a 70 mm space between the section rear panel and the wall in order to provide the possibility of central post rear panel disassembly.

8.2 Installation tools

Use the following tools during the installation:

- 1.2÷1.5 kW hammer drill;
- Ø16 mm hard-alloyed drill bit for anchor bolt sleeves;
- floor chaser for cable raceways;
- PH2 Philips screwdriver;
- S17 open-end and socket wrenches;
- SW2, SW4, SW5 Allen wrench;
- level;
- measuring tape 2 m;
- slide caliper.



Note:

It is allowed to use other equipment and measuring tools provided the equipment in use ensures the required parameters and measurement accuracy.

8.3 Cable length

Table 5. Cables used at the installation

No	Equipment	Cable length, m, max	Cable type	Cross-section, mm, min	Example
1	Power supply	10	Twin cable	1.5	AWG 15; HO5VV-F 2×1.5
		20	Twin cable	2.5	AWG 13; HO5VV-F 2×2.5
2	- Fire Alarm device - Optional equipment to control board input and output	30	Twin cable	0.2	RAMCRO SS22AF-T 2×0.22 CQR-2
3	RC-panel	40	Eight core cable	0.2	CQR CABS8 8×0.22c
4	ACS-controller	30	Six core cable	0.2	CQR CABS6 6×0.22c

8.4 Installation order

Installation order is described with regards to recommendations, given in Sect. 8.1. Installation tools are listed in Sect. 8.2. Figure numbers are given in accordance with Fig. 8 and 9.

Speed gate connection layout is given in Fig. 20. Types of cables used are stated in Sect. 8.3. The example of **ST-01** and **STD-01** connection layout with extra passage lane arrangement is shown in Fig. 19.

Follow this order to install the speed gate:

1. Install the PS on a designated area in accordance with the instruction given in the operational documentation.



Attention!

- While relocating the section, it is forbidden to hold it by the top cover (10).
- Installation and fastening of the speed gate sections should be performed only after cabling in cable channels and inside of the speed gate being finished.
- Be careful while dismantling the section pieces that has not been fixed on a mounting surface. Prevent the section from falling down and its pieces from being damaged.

2. Determine the installation location for *Master* and *Slave* sections and for double-sided section if needed. However, it is necessary to consider the sections relative positioning: the *Master* section panel (side of the double-sided section) should always been placed opposite to the *Slave* section panel (side of the double-sided section).
3. Mark and drill holes for anchor sleeves on the mounting surface for fastening speed gate sections in accordance with the layouts presented in Fig. 17-18 and in compliance with the checkpoint design. Use Ø16 mm hard-alloyed drill bit. The drilling depth for standard M10 anchor should be 65 mm. Insert the anchor sleeves in the holes so they are flush with the floor surface.

4. Prepare cable channels in the floor:
 - Channels for cabling from external devices (PS, RC-panel or ACS-controller, Fire Alarm device etc.) – to input holes of the *Master* section and input towards double-sided *Master* section;
 - Channels that link input holes of the opposite sections (double-sided sections) of one passage lane – for routing DC and CAN cables.



Attention!

Passage lanes that are limited by one-sided sections and / or sides of double-sided sections are standalone devices which are not connected to each other.

Master and *Slave* sides of one double-sided section are electrically independent as they belong to different passage lanes.

5. In the cable channels, route cables from external devices to the sections installation location. Also, route flexible conduit in the cable channel between the opposite sections (sides of the sections) for each passage lane. The flexible conduit is used for pulling DC and CAN cables from the *Slave* section (side of the section) to the *Master* section (side of the section).



Note:

When it is impossible to use flexible conduit for cabling, then it is necessary to route DC and CAN cables prior to the sections installation. These cables are located under the housing of the *Slave* section central post (side of the section). To do so it is necessary to unpack the *Slave* section, dismantle the housing of the central post (see Fig. 21), take out DC and CAN cables and disconnect them from the drive control board. There are numbers on the cut-off ends of the core that correspond to the connection layout (Fig. 20).

6. Unpack the *Master* section (box №1, **ST-01/M**). Do not work alone! Carefully take the section out of the box by holding it by the top duct.
7. Unpack the section top covers (packed in a separate box).
8. Dismantle parts of the speed gate section as described:
 - Remove the central post cover plate (5) (Fig. 21, Sect. 8.9.1).
 - Dismantle the front panels of both side posts (8) (Fig. 22, Sect. 8.9.2). Prior to this - disconnect the connection cable from the front-end indication block.
9. Install the speed gate section on the anchor sleeves. Do not work alone!
10. Route cables through the hole located in the base of the *Master* central post: from PS (16), RC-panel (17), Fire Alarm device (18) and from the optional equipment. Route DC (19) and CAN (20) cables from the *Slave* section (side of the section) or a flexible conduit for cabling.
11. Fix the section on the mounting surface by using eleven M10 bolts with washers. Align the vertical position of the speed gate section with a level. Minimum angle measured from the vertical of the section should not exceed 0.5°. It is allowed to use mounting gaskets.



Note:

Points 12-16 should be applied for **STD-01** double-sided section installation.

12. Unpack and install the double-sided section. Act as described in points 7 - 9 (for both sides of the section). Place the double-sided section so its *Slave* side stands towards the installed *Master* section.
13. Take DC and CAN connection cables out of the central post of the double-sided section from the *Slave* side (if they hadn't been routed in the cable channel earlier). Lead them through the hole that is located on the base of the post. Route cables with a flexible conduit to the *Master* section.
14. Route cables for controlling the second passage lane by using the hole located in the base plate of the double-section central post (from the *Master* section side): from PS, from RC-panel or ACS-controller, from the Fire Alarm device and from optional equipment. Route DC (19) and CAN (20) cables from the *Slave* section (side of the section) or a flexible conduit for cabling.
15. Align the vertical position of the double-sided section and fix it on the mounting surface by using 14 M10 bolts with washers (see point 11).

16. Install other double-sided sections if needed (points 12 - 15).
17. Unpack and install the speed gate *Slave* section. Proceed as described in points 7 - 9.
18. Take DC and CAN cables out of the *Slave* section (if they hadn't been routed in the cable channel earlier). Lead them through the hole that is located in the post base plate. Route cables with a flexible conduit to the *Master* section.
19. Align the vertical position of the section and fix it on the mounting surface (see point 11).
20. Connect cables to the control board of the first passage lane according to the speed gate electric connection layout (see Fig. 11 and Fig. 20). The control board is located in the bottom side of the *Master* section central post.



Note:

DC (2) and CAN (4) cables should be connected to the **X5** terminal blocks of the *Master* section control board and to **X1** terminal blocks of the *Slave* section drive board in accordance with the conduit marking (see Fig. 20).

21. If needed, access card reader can be installed in the special openings inside the top duct of the side posts (see Fig. 22) or the reader is to be stuck to the top cover underneath the indication block. Use the double-sided tape to fix readers and, if needed, non-metal pads for the reader to be placed as close to the top cover as possible in order to increase the read range. Carefully route reader cables through the top duct into the central post where the ACS-controller cable is to be led through the default holes. Cables should not be routed between or near the holes used for fastening the section top cover. This will prevent the cables from damage. Use self-adhesive cable tie mounts for cable fastening. It is prohibited to fix cables to the internal wiring cables and to the control boards of the intrusion detectors. It is also prohibited to route cables near the control boards where the detectors are located.



Attention!

Access card readers **are not included** in the standard delivery set of the turnstile!

The selection of the readers, its purchase and installation into the product is carried out by the customer (installer) in accordance with the checkpoint design and the characteristics of the access control system and the control controller. It is possible to install readers as manufactured by **PERCo (IR13, IR19)**, and third-party manufacturers.

Readers must meet the following requirements:

Overall dimensions (length × width × height)	max 155×68×28 mm
Read range	min 40 mm

provided that the reader is located as close to the top cover as possible.

22. Unpack the glass swing panels (1) and mount them (Fig. 23, Sect. 8.9.3).
23. Mount swing panel cover plate (4) from installation kit (Fig. 23, Sect. 8.9.4).
24. Mount front panels (8) (Sect. 8.9.2). After installation make sure that the top edges of the panels are flush with the section housing. Front-end indication block panel should be installed where indication control module is located. This module is fixed to one of the two steel protection plates in the top duct (see Fig. 22). However, the front-end indication block is to be connected to the indication control module with a connection cable. The connection cable connected to the **ARROW** connector of the indication control module will activate the white arrow on the front-end indication blocks. The cable connected to the **CROSS** connector will activate the red cross (Sect. 5.2.2, 8.9.2, Fig. 22).
25. Mount central post indication blocks (3) (see Fig. 24, Sect. 8.9.5) (included in the installation kit).
26. Install section top covers (10) (see Fig. 25, 26 Sect. 8.9.6).
27. Use switches on the *Master* section control board (side of the section) (see Sect. 5.2.4) in order to:
 - Set speed gate operating mode by using the **Pulse** switch.
 - Select the rotation direction of swing panels as an alarm reaction to the Fire Alarm device. Use the **FA Dir** switch.
 - Set the size of swing panels that will be mounted for the passage lane by using **Size1**, **Size2** switches (see Table 1).

28. Perform a test run as described in Sect. 9.1.

29. If needed, adjust the level of swing panels relative to each other and set the speed gate into training mode, then close the swing panels manually as described in Sect. 8.7.
30. Check the speed gate correct operation by sending commands from the RC-panel (see Sect. 9.2, 9.3).
31. Execute operations, in the same way as described in points 20 – 30, for all other passage lanes.
32. Mount central post cover plate (5) (Sect. 8.9.1).

The speed gate is ready for operation once the installation and testing are finished.

8.5 Mounting surface marking layouts

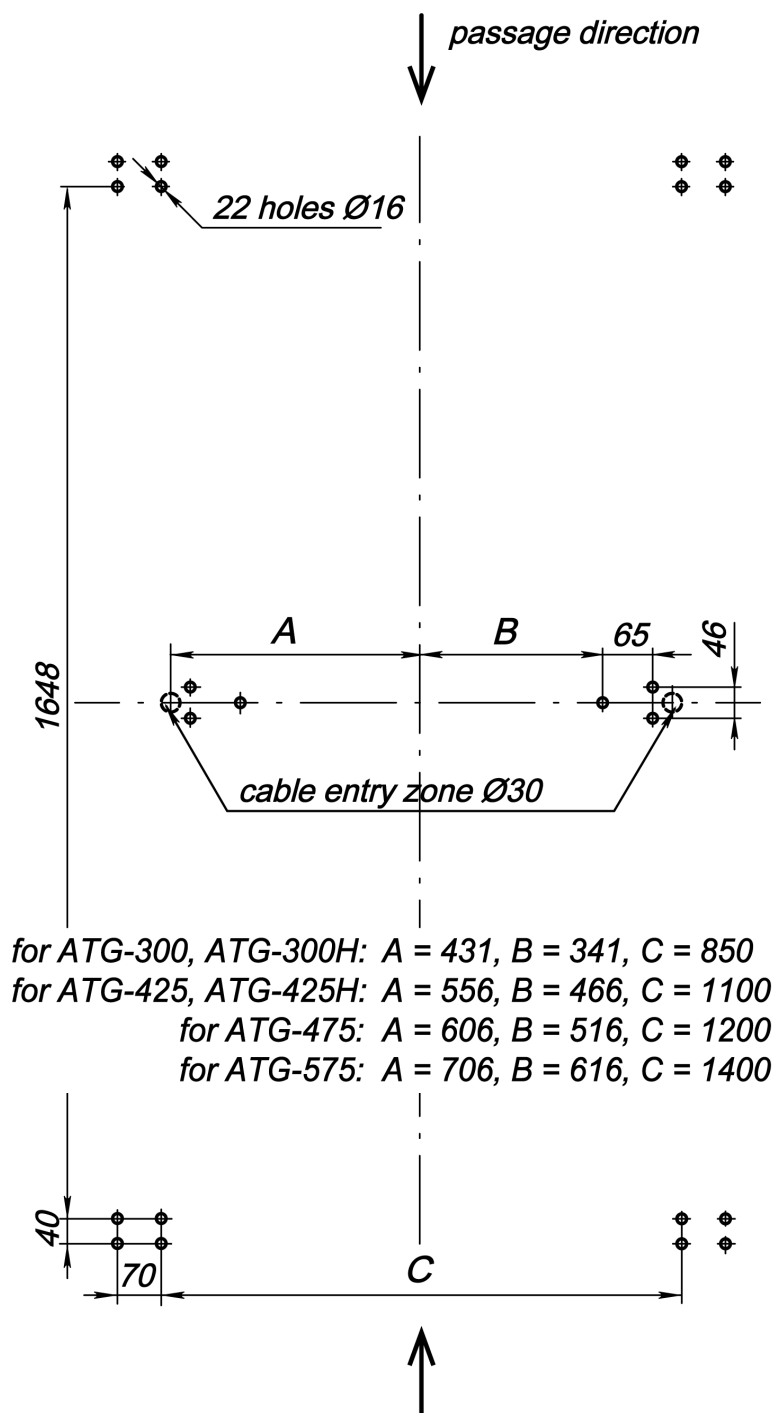

Figure 17. Speed gate marking layout¹

¹ The diameter of the holes in the diagram is indicated for anchors of the PFG IR10 "SORMAT" type; when using other types of anchors, it is necessary to make holes of corresponding sizes.

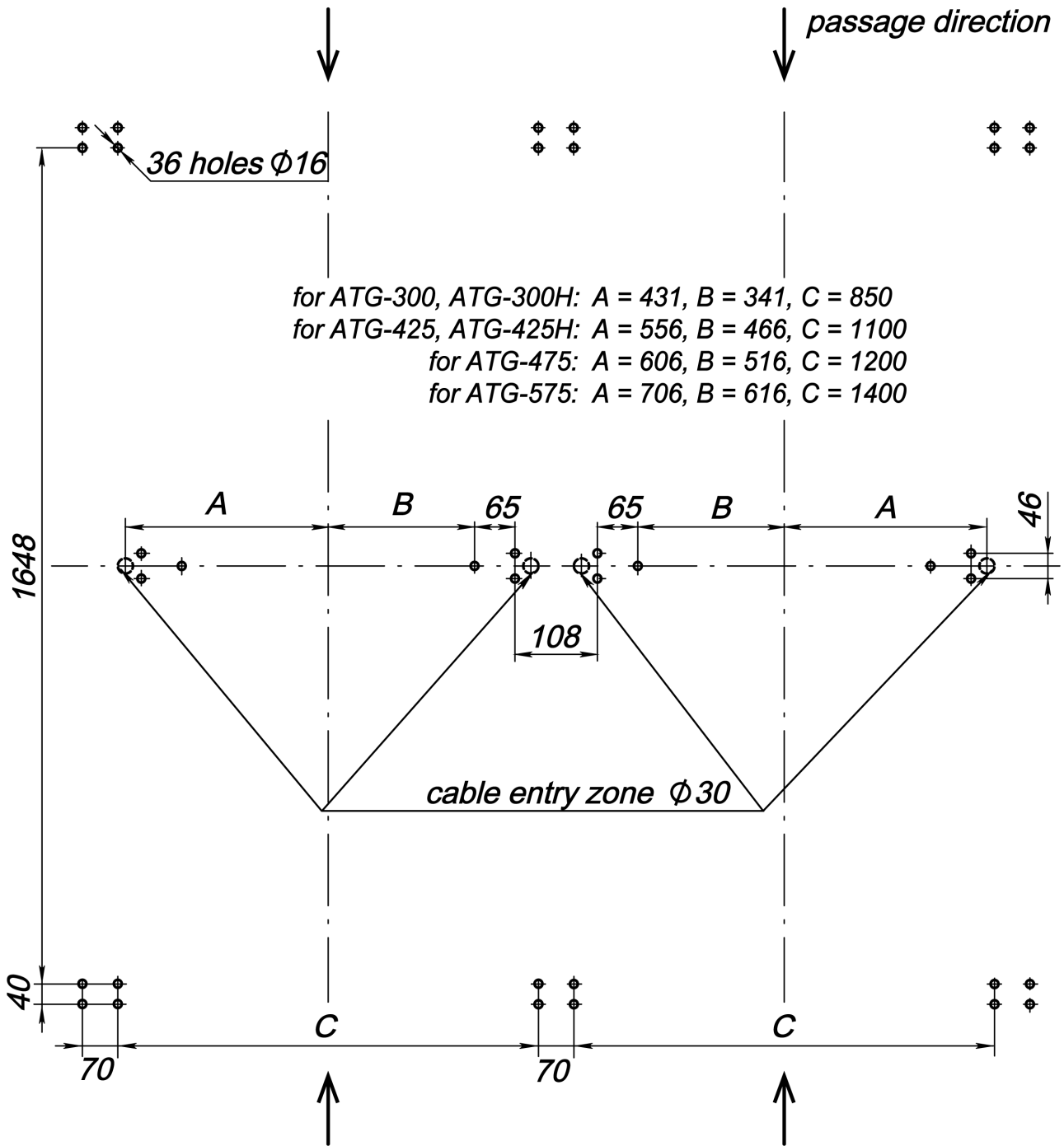

Figure 18. Speed gate and double-sided section marking layout¹

¹ The diameter of the holes in the diagram is indicated for anchors of the PFG IR10 "SORMAT" type; when using other types of anchors, it is necessary to make holes of corresponding sizes.

8.6 Speed gate wiring diagram

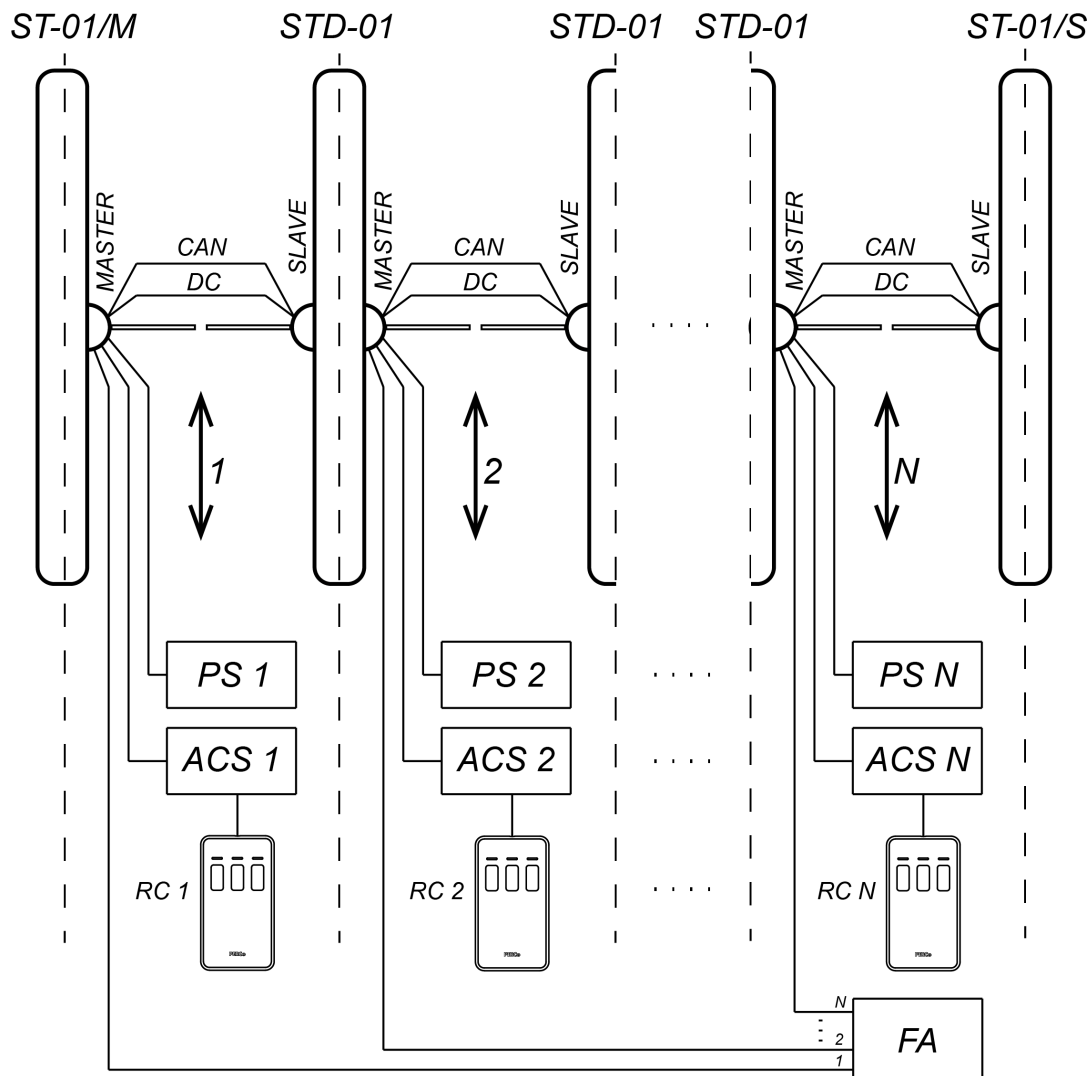

Figure 19. ST-01 speed gate and STD-01 double-sided section wiring diagram

Table 6. List of the elements of speed gate wiring diagram

Legend	Name	Nr, pc.
A1	Master section (section side)	1
A1.1	ST-01.771 control board	1
A1.2	ST-01.761 drive control board, Master section (section side)	1
A2	Slave section (section side)	1
A2.1	ST-01.761 drive control board, Slave section (section side)	1
A3	RC-panel	1
A4 ¹	Speed gate PS	1
A5 ¹	Fire Alarm signal sending device	1
A6.1 ¹ , A6.2 ¹	ACS-controller	1
A7 ¹	Wireless remote control	1
A8 ¹	12V DC siren	1
A9.1 ¹ , A9.2 ¹	Remote indication block	2
A10 ¹	Remote indicators PS	1
1, 2	DC connection cable	2
3, 4	CAN connection cable	2
5	Wire jumper in case there is no Fire Alarm (A5). Installed by default.	1

¹ The equipment is not included in the standard delivery set.

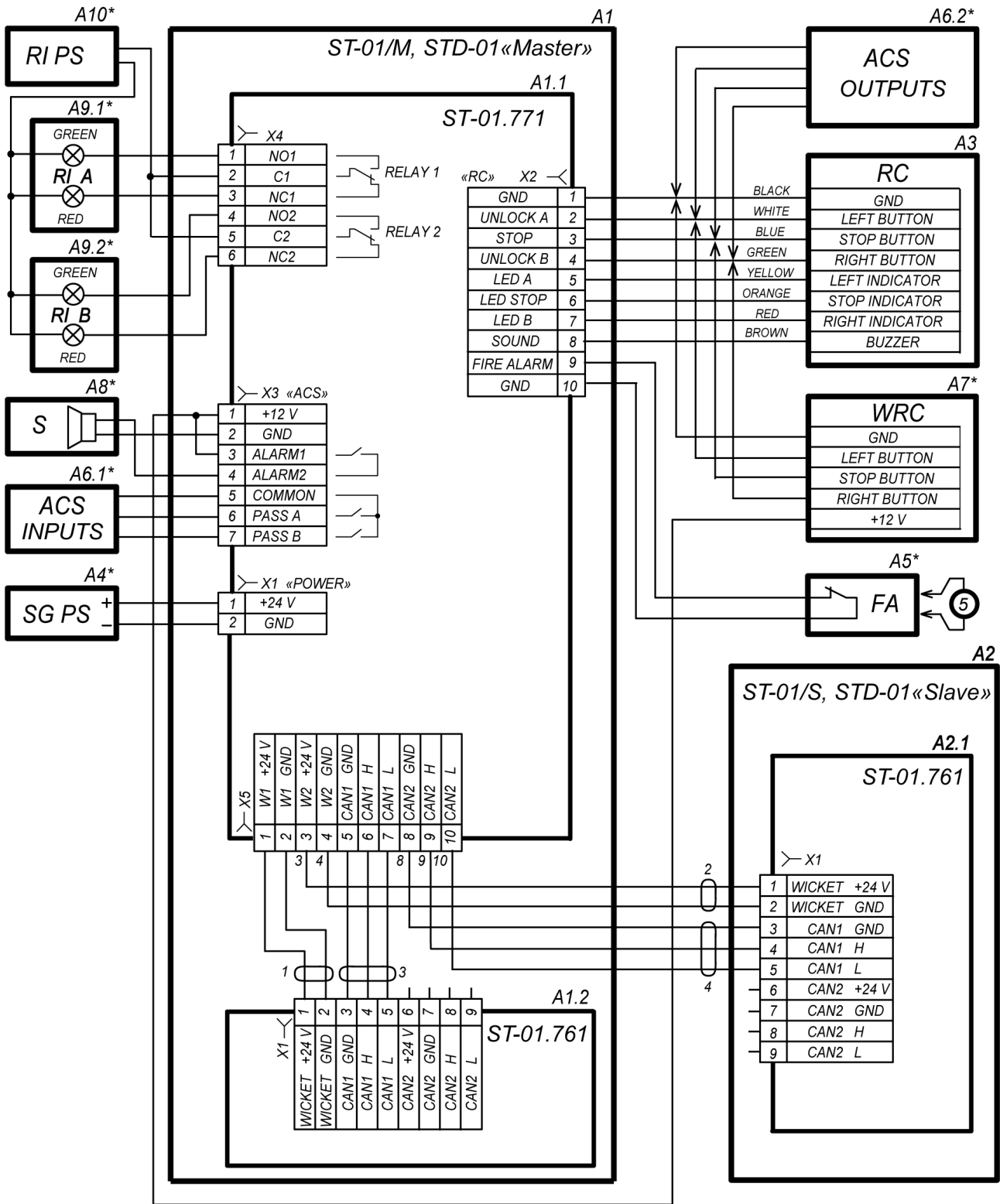

Figure 20. Speed gate wiring diagram¹



Attention!

It is recommended to make the FA input galvanically independent from the fire alarm and from other turnstiles.

¹ The list of elements is given in table 6.

Equipment marked with an asterisk (*) is not included in the standard package.

When operating the turnstile as part of an ACS, it is recommended to connect the remote control (A3) to the ACS controller in accordance with the operating documentation of the controller.

8.7 Training mode

The mode allows adjusting manually speed gate swing gates initial position. Proceed as follows:

- 1 Turn off the speed gate power supply.
- 2 Switch the **R2** switch to the **ON** position (**R1** switch should be in **OFF** position).
- 3 Arrange the swing panels into the required initial position and adjust them relatively to each other.
- 4 Turn on the speed gate power supply. The swing panel will make a search for the end positions and get back into the initial position. The swing panel position data will be registered in the control board memory.



Note:

If in the training mode the speed gate switches into the “*Emergency*” mode, that indicates the incorrect initial position of the swing panels. Turn off the speed gate power supply in order to exit the “*Emergency*” mode. In order to continue with the training mode, install the swing panels into the initial (locked) position and turn on the speed gate power supply.

- 5 Turn off the speed gate power supply.
- 6 Switch the **R2** switch to the **OFF** on the control board.
- 7 Turn on the speed gate power supply. The swing panels will make a search for the end positions and get back into the initial (locked) position. The speed gate is ready for operation.

8.8 “Auto-opening in the selected direction” mode

This additional operating mode is used, when it is required to organize free entrance (or exit) keeping the swing panels in closed position and to prevent an unauthorized access in the opposite direction (e.g. in the sales area of the store etc.).

Selection of the operating modes can be performed by switching **R1** and **R2** switches on the control board (see Fig. 11 and Table 2).



Attention!

Change the position of the switches only when the speed gate is turned off.

This operating mode allows to organize the free passage in one preselected direction, when the swing panels automatically open and close after the passage. In the direction selected for the “*Auto-opening*” mode, if the speed gate is not occupied for passage from the opposite direction, the green indicator (passage granting) is constantly lit, but in the other direction of the passage the red indicator (passage denial) is lit. In case if the passage from the opposite direction is authorized (from RC-panel, WRC-kit or ACS-controller), the “*Auto-opening*” mode is turned off for the time of this passage.

Mode operation algorithm:

- 1) By default, the green indication is on in the “*Auto-opening in the selected direction*” mode in free passage direction and the red indication is on in the other direction. RC commands or ACS-controller commands for the passage in the “*Auto-opening in the selected direction*” mode are ignored.
- 2) The intrusion detectors send a command to the speed gate controller to open the swing panels when the visitor walks through the passage lane in the “*Auto-opening in the selected direction*” mode direction. The swing panels open in this direction, and when the passage is completed, the intrusion detectors send a command to the controller and the swing panels automatically close. The indication stays in its initial state.
- 3) When the passage is performed in the direction opposite to “*Auto-opening in the selected direction*” mode direction – the operation algorithm is equal to the ordinary algorithm (Sect. 5.2.7). During the authorized passage, the “*Auto-opening in the selected direction*” mode switches off for the passage waiting period. If the “*Free passage*” mode is applied for this direction, then the passage waiting period will be deactivated while this mode is applied.
- 4) All other cases such as simultaneous passage in both directions are considered as abnormal and then the controller will generate an emergency signal and will close the swing panels.

8.9 Assembly and disassembly of the speed gate components



Attention!

Speed gate components are made of polished stainless steel and glass. Be careful during the assembly, to prevent the components from falling and damage, place them on an even and steady surface, prevent them from scratches.

8.9.1 Central post cover plate

To remove the central post cover plate (5), pull the cover plate down along the post, take it aside from the post, bringing the hooks from slots in the central post (Fig. 21).

Central post cover plate is to be installed in the reverse order.

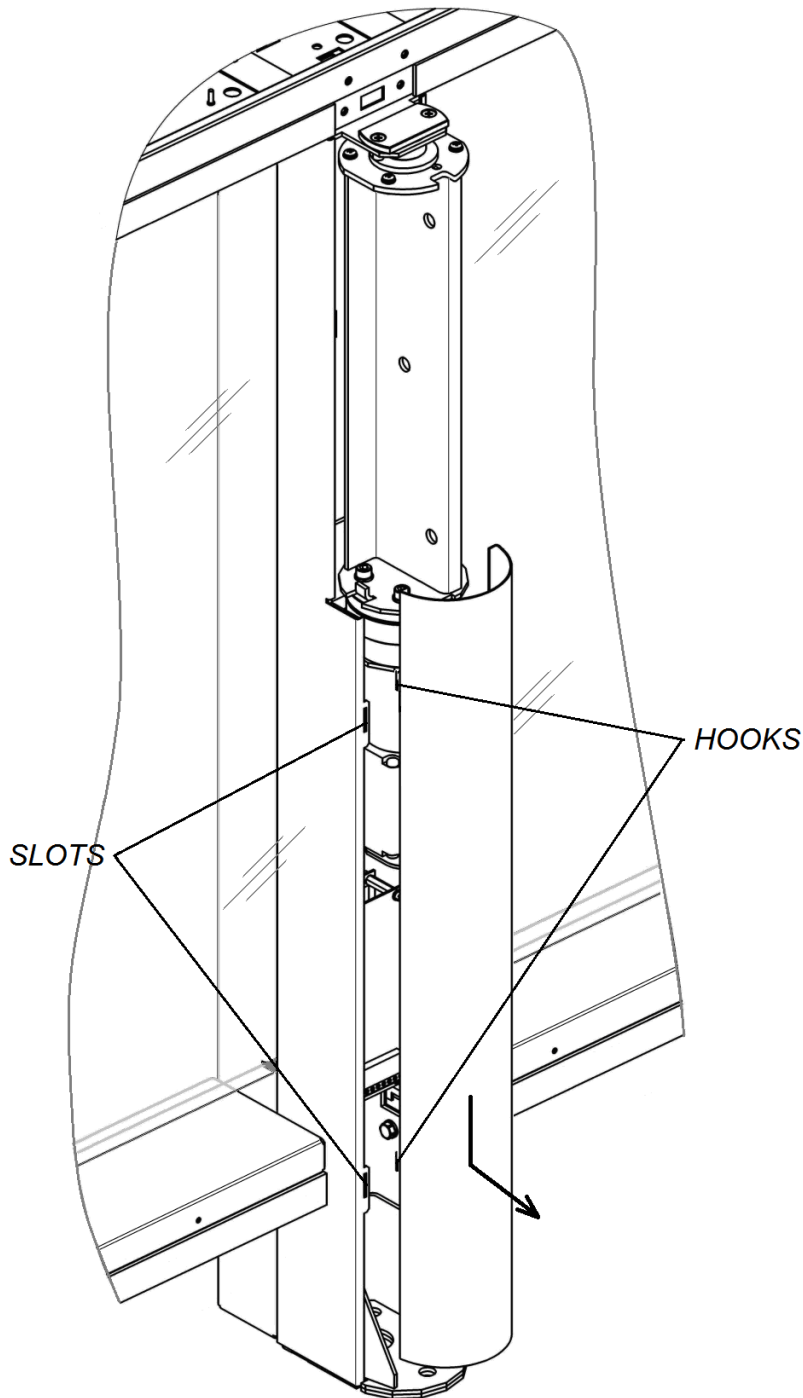

Figure 21. Central post cover plate disassembly

8.9.2 Front panel of the side post

Remove the side post front panel (8), moving it up along the post and then pull it, bringing the hooks from slots in the side post (Fig. 22). Be careful not to damage the connection cable! Disconnect the connection cable output from the front-end indication block.

Side post front panel assembly is to be installed in the reverse order.

Prior to mounting (removing) the side post panel, section top cover (10) is to be removed first (see Sect. 8.9.6).

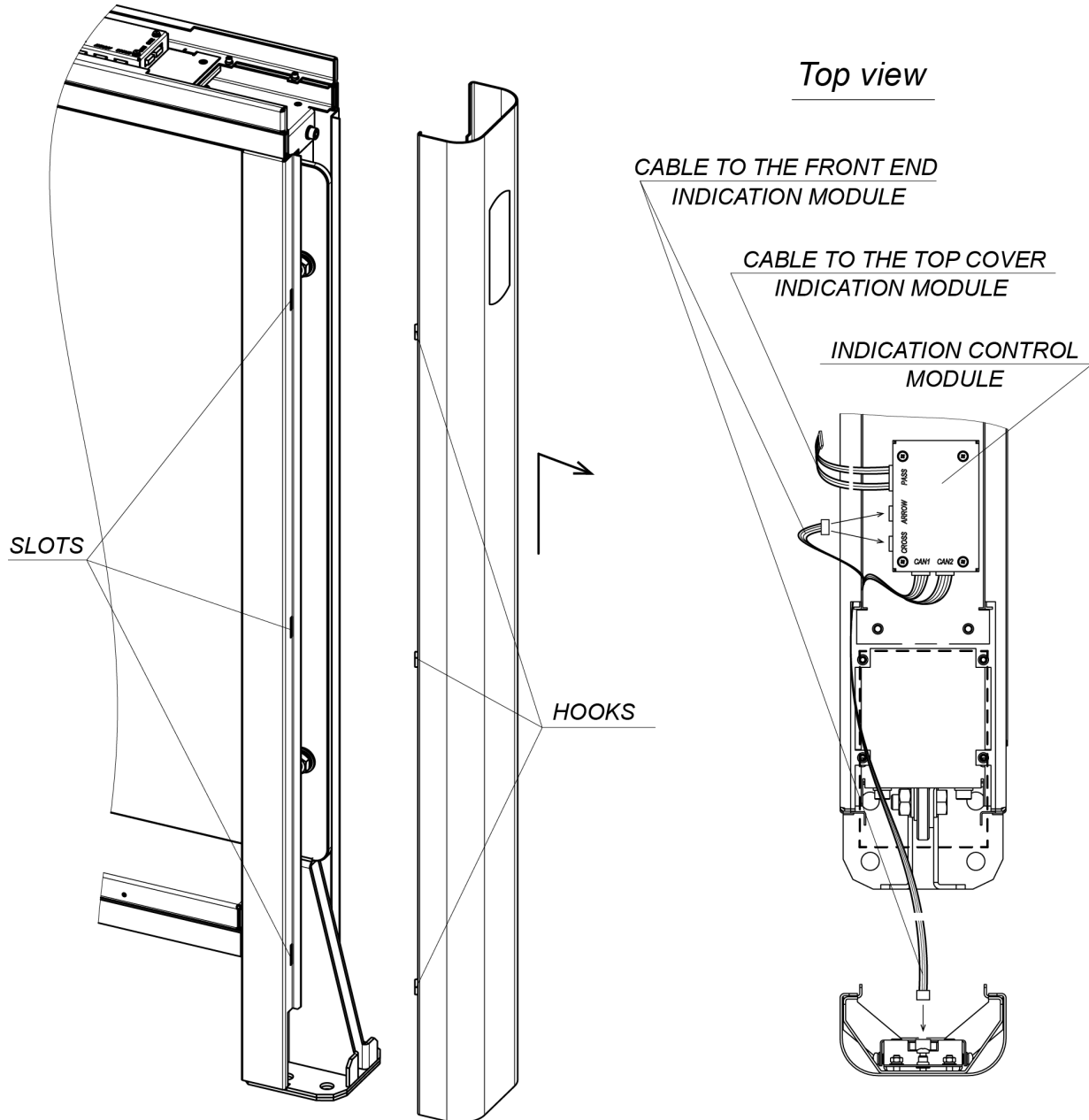

Figure 22. Side post front panel disassembly
(the dashed line shows the location of the reader)

8.9.3 Swing panel

Two people shall install and remove the swing panels. The swing panel is fixed to the rotating support in three places with M10×30 bolts, 10 washers, plastic bushing and M10 screws (Fig. 23). Use S17 open end wrenches.

8.9.4 Swing panel cover plate

Swing panel cover plate (4) consists of two parts. In order to install the cover plate, proceed as follows:

1. Turn fully the rotating support of swing panel in the clockwise direction.
2. Assemble one of the cover plate components on the rotating support. In order to do that, mount the cover plate on the upper plate of the rotating support through the slots in the upper part of the cover plate. After that, shift the cover plate down to the end, mounting the bottom cover plate mortise into a tenon, located in the bottom part of the rotating support (Fig. 23).
3. Fix the installed part of the cover plate with a Philips screwdriver to the rotating support with two M4×10 screws with washers from the delivery set.
4. Turn fully the rotating support of swing panel in the counterclockwise direction. Mount the second part of the cover plate likewise.
5. Check the gaps between swing panel and its cover plates, between swing panel cover plates and central post cover plate, if needed, loosen the M4×10 screws and adjust the bottom part of the panel cover plate. Tighten the screws.

Panel cover plate removal is performed in a reverse order. Prior to removal, disassemble of central post indication block is required (see Sect. 8.9.5).

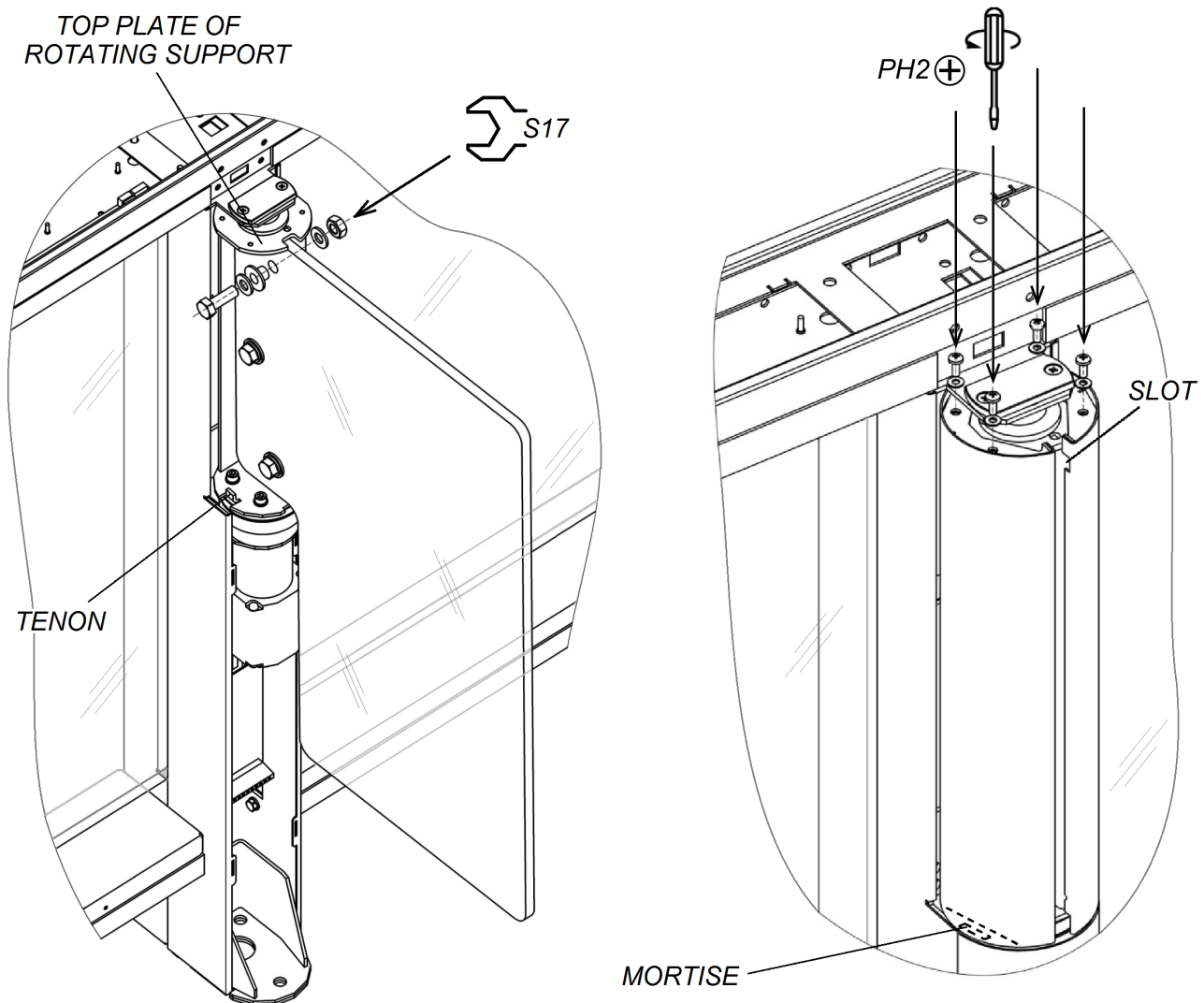

Figure 23. Swing panel and its cover plate

8.9.5 Central post indication block

In order to install the central post indication block (3), proceed as follows (Fig. 24):

1. Pull the cable from central post indication block into the post top duct through the hole above the central post.
2. Pull the cable under the jumper in the duct and connect it to **LED** output.
3. Install the indication block on the surface, located above the rotating support of swing panel and using an SW4 Allen wrench fix it on the post top duct (12), using two M5×12 screws with washers from the delivery set.
4. Check the evenness of the gap between the indications module and the swing panel cover plate, loosen the M4×10 screws and tighten them if needed.

Remove the central post indication block in a reverse order. Disassemble the section top cover (10) and two shielding plates prior to removal (Sect. 8.9.6, Fig. 24, Fig. 25).

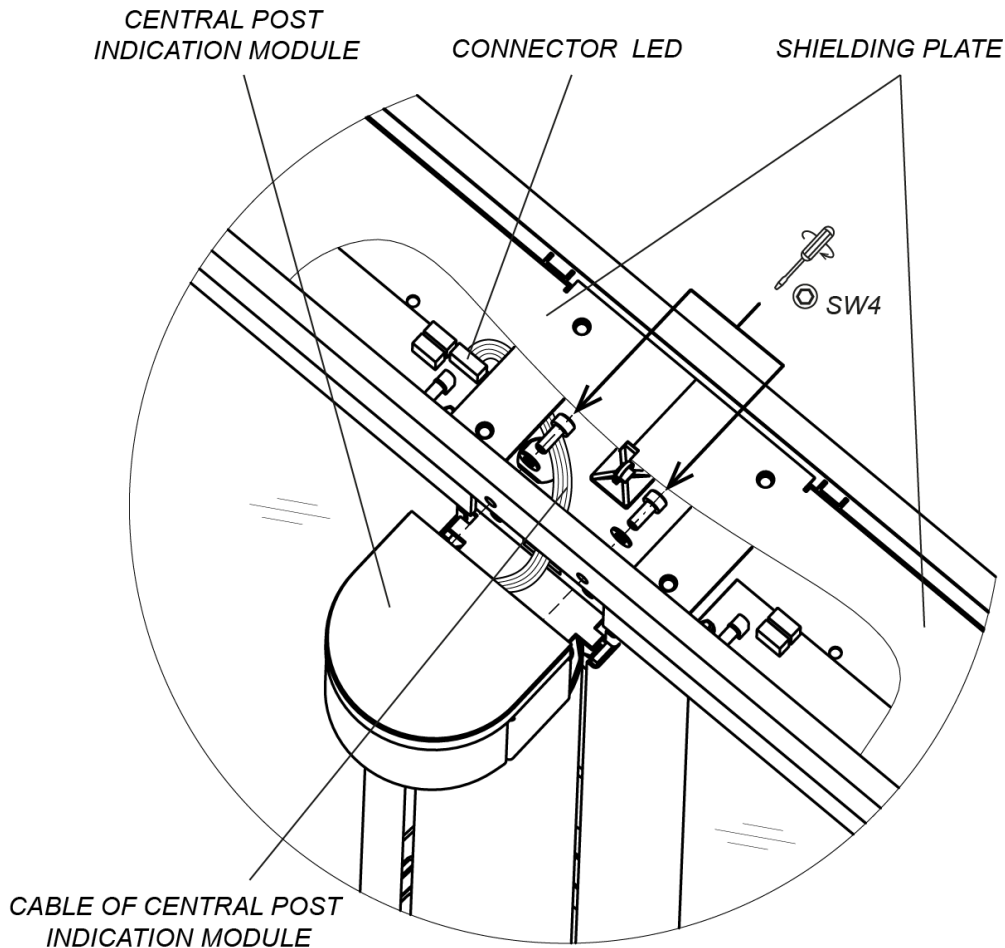

Figure 24. Central post indication block installation

8.9.6 Section top cover

Prior to installation of the section top cover (10), check whether all cables have been properly connected to the indication control module (see Fig. 22, Sect. 8.9.2).

Installation order of the **STC-01G (SDC-01G)** and **STC-01S (SDC-01S)** section top covers (see Fig. 25):

- Connect the connection cable from the indication control module (“PASS” connector, Fig. 22) to the top cover indication block (for **STC-01G, SDC-01G**).
- Carefully lay down the cover on top of the housing, the fixing brackets should lean on the protection plates. **To prevent the cables from the damage, ensure that they do not get stuck between the fixing brackets and protection plates!**
- Fasten eight M5×16 screws and washers using a SW4 Allen wrench included in the installation kit through the holes in the bottom part of the top duct of the section.

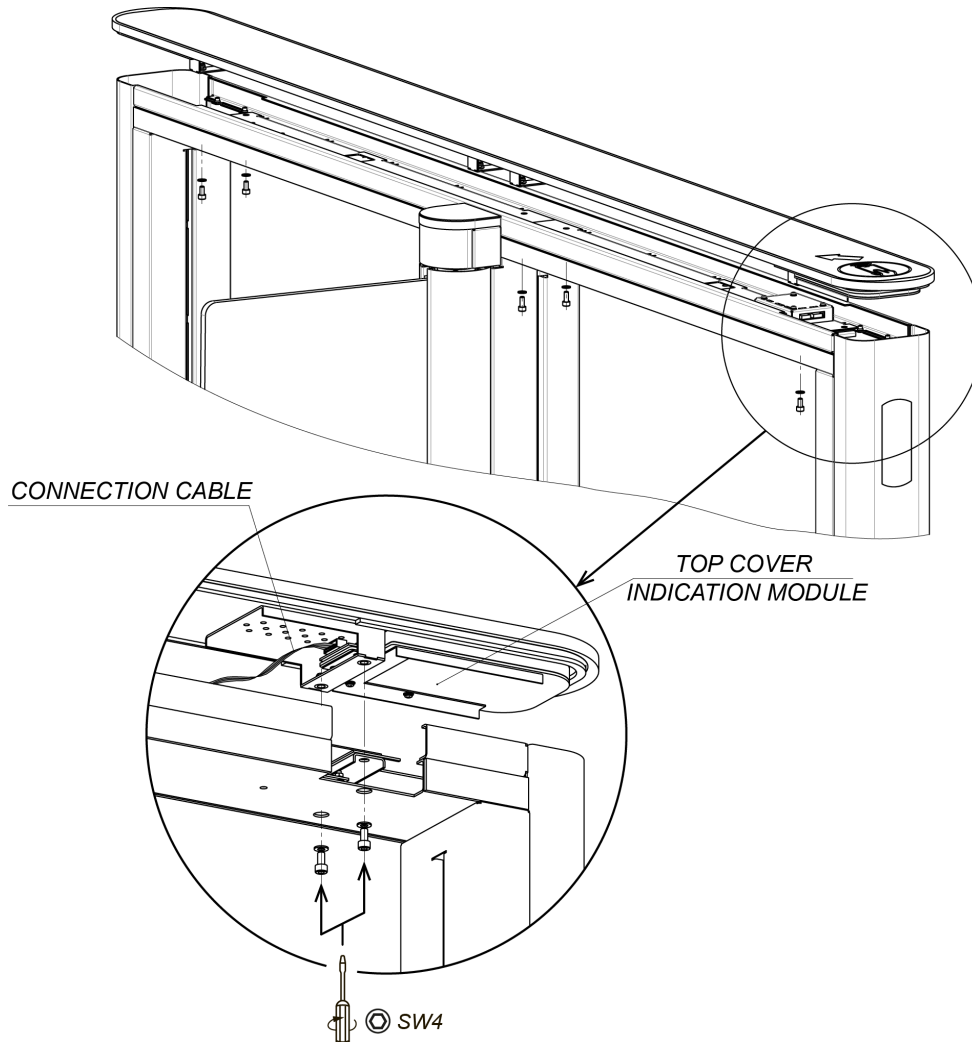

Figure 25. Installation of the *STC-01G (SDC-01G)* section top cover

Installation order of the **STC-01GS (SDC-01GS)** section top covers (see Fig. 26):

- Take one glass piece of the top cover featuring an indication block and connect the connection cable of the indication control module (“PASS” connector, Fig. 22) to the top cover indication block.
- Carefully lay down the cover on top of the housing, the fixing brackets should lean on the protection plates. **To prevent the cables from the damage, ensure that they do not get stuck between the fixing brackets and protection plates!** Using SW4 Allen wrench fasten the top cover piece with two M5×16 screws with washers included into installation kit through the holes in the bottom part of the section top duct. Do not tighten fully the screws in order to be able to adjust them further.
- Mount the other glass top cover piece similarly.

- Install the additional equipment on the metal insert of the top cover.
- Route the additional equipment connection cables through the central post to their connection point.
- Mount the central insert with additional equipment on its place, fix it with two M5×16 screws using a SW4 Allen wrench. Tighten the screws preliminarily.
- Adjust the top cover pieces relatively to the speed gate housing and to one another. Tighten fully the top cover fixation screws.

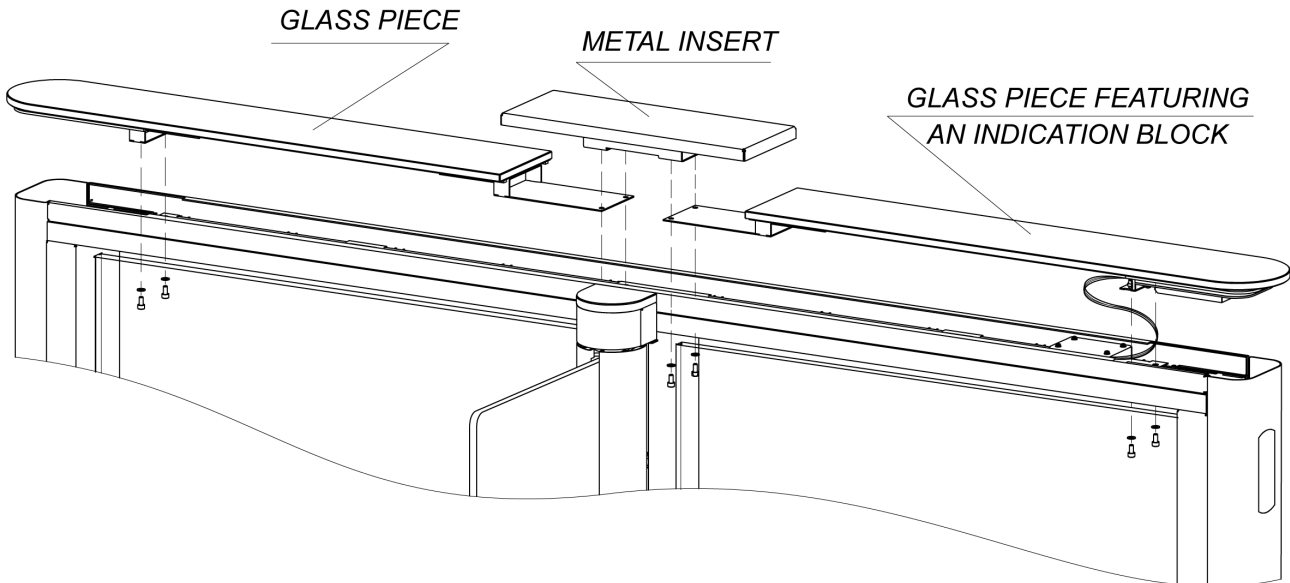

Figure 26. Installation of the STC-01GS (SDC-01GS) section top cover

Do not work alone! During the installation pay attention to the gaps between the top cover and the duct along the whole perimeter, repeat steps again, if necessary.

Remove the top cover in the reverse order.



Attention!

During long-term and intensive operation of the turnstile with built-in readers, scratches and scuff marks can appear on the glass surface either from access cards presentation (as well as from wallets, bags, wristbands, watches, rings, etc.) or from cleaning substances with abrasive inclusion.

Such damages are not a warranty case.

In order to prevent or remove such damages manufacturer has provided self-adhesive rubber pads for card presentation areas (see Fig. 27). Moreover, the customer can use the services of special companies providing professional glass polishing or purchase new covers for replacement from **PERCo**.

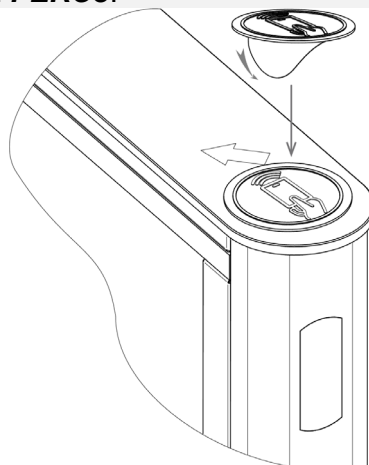

Figure 27. Gluing rubber cover on glass cover

8.9.7 Bottom duct cover

Section bottom duct has two covers (14). Boards with intrusion detectors are located in the duct.

To remove one bottom duct cover, using a SW2 Allen wrench loosen the screws fixing the cover (Fig. 28), then lift the front end of the cover, unhook the rear edge of the cover from the fixing hooks and remove it. Bottom duct cover installation is performed in the reverse order.

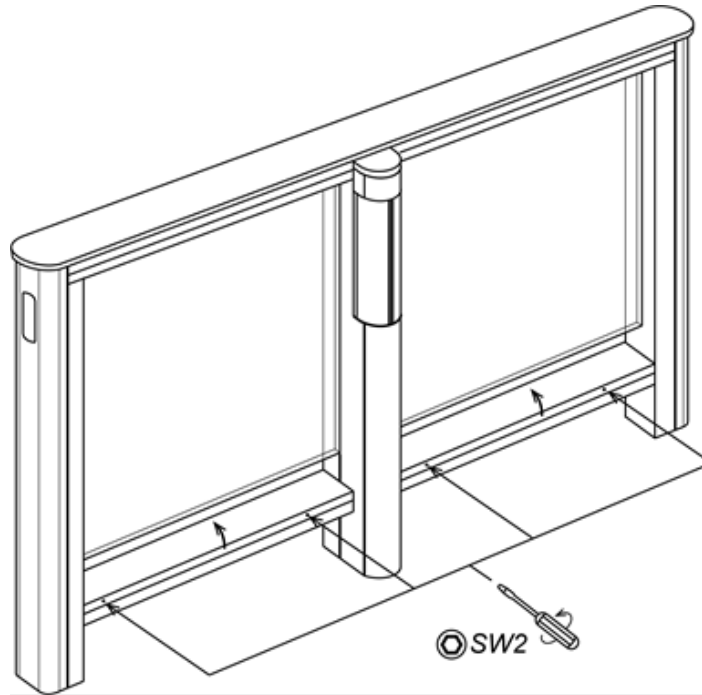

Figure 28. Bottom duct cover disassembly

8.9.8 Filling glass



Attention!

Be careful during the filling glass replacement, prevent it from falling and do not hit it against the metallic elements of the section. All the works should be carried out by two people.

In order to replace the filling glass of the section (13), proceed as follows:

1. Remove the section top cover (10) (Sect. 8.9.6) and two protection plates.
2. Remove the indication block of the central post (3) (Sect. 8.9.5).
3. Remove the swing panel cover plate (4) (Sect. 8.9.4).
4. Remove the central post cover plate (5) (Sect. 8.9.1).
5. Remove both covers from the bottom duct (14) (Sect. 8.9.7).
6. For **ST-01** section: remove the central post rear panel (6). Unscrew 2 M6×16 screws (for SW5 Allen wrench) in the bottom ducts, M6×16 screws (for SW5 Allen wrench) at the bottom of the central post and 2 M5×12 screws (for SW4 Allen wrench) in the top duct (Fig. 31).
For **STD-01** section: follow the instructions described in points 2-4 for the second side of the section.
7. Remove the front panels (8) from both posts.
8. Using S17 open-end and Allen wrenches, unscrew and remove 6 M10×30 screws with washers, plastic bushing and screws fixing the filling glass (two in each bracket of the side posts and two in the central post) (see Fig. 29, 30).
9. Pull the filling glass out to one side from the side post until its other side gets out of the second side post. Keep the glass from falling when performing the removal!
10. Shift the free end of the glass aside and take out the second end of the glass from the side section. The glass is disassembled.
11. Install the new filling glass in the reverse order.

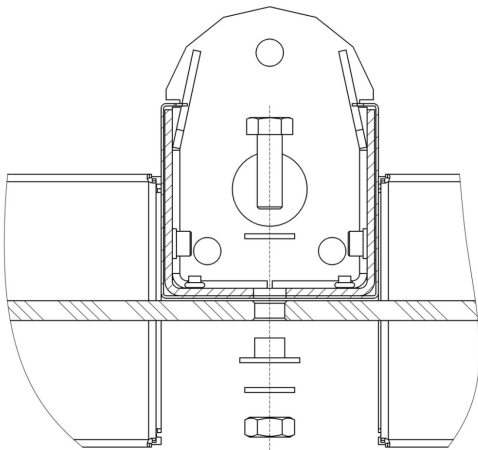

Figure 29. Filling glass fixing in the ST-01 central post

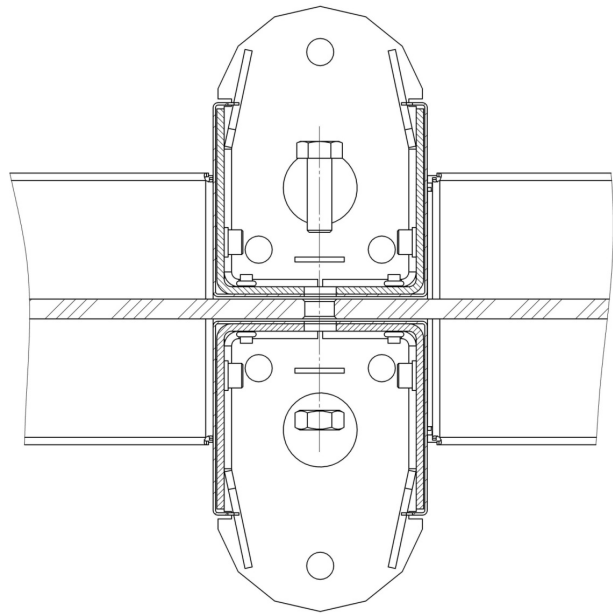

Figure 30. Filling glass fixing in the central post of the double-sided section STD-01

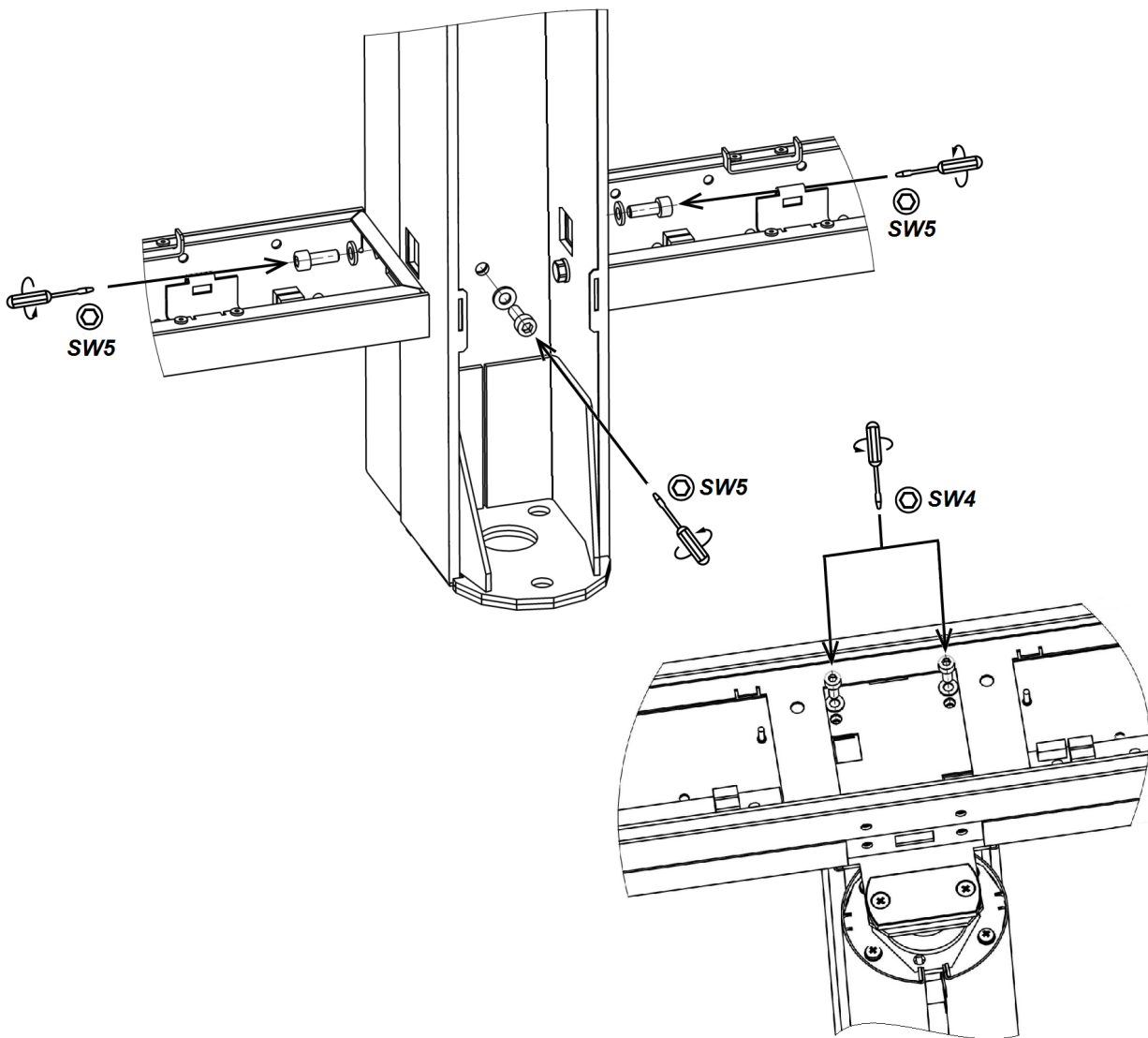

Figure 31. Central post rear panel disassembly

9 OPERATION

Follow the instructions of speed gate operation in accordance with Sect. 7.2.



Attention!

- Do not move through the speed gate passage area any objects with dimensions exceeding the width of the passage lane.
- Do not jerk and hit any elements of the speed gate to prevent their mechanical deformation.
- Do not dismantle or adjust mechanisms, ensuring the speed gate operation.
- Do not use substances that may cause mechanical damage or corrosion of the surface for speed gate cleaning.



Cleaning and Maintenance of Stainless Steel Products:

The anti-corrosion effect of stainless steel depends on the state of the thin oxide layer on its surface. Therefore, for its cleaning and maintenance, it is necessary to use soft lint-free cloths and non-abrasive neutral detergents. It is not allowed to use coarse and stiff sponges, brushes, and other items that can scratch the product surface. Avoid cleaners containing chlorides, ammonia, and other reagents that can damage the oxide film.

To remove tough stains from stainless steel, use non-abrasive products specially designed for this purpose according to their instructions (for instance, "E-NOX Clean" or similar).

After treatment, wash off the remaining detergents with clean water and dry the treated surfaces. During the product operation, it is recommended to use special stainless steel protection products containing neutral oils (for instance, "Glutoclean" or similar).

9.1 Power-up



Attention!

Before speed gate power-up make sure that the passage lane is free and nothing interferes with the swing panels movement.

In order to power up the speed gate, proceed as follows:

1. Connect the speed gate power supply unit to the AC outlet with the voltage and frequency rating complying with the certificate for the power supply unit.
2. Switch on the speed gate power supply unit. Speed gate swing panels get automatically set into an initial (locked) position.
3. At pulse control mode the "Always locked" command is sent automatically, at the potential control mode – "Always locked" command is sent automatically (Tables 7 and 8) until another command is sent from the external controller. The speed gate is ready for operation.

9.2 Pulse control mode

Speed gate control command sending from the RC-panel and its indication on the speed gate sections is performed in accordance with Table 7. Passage directions are independent of each other, i.e. sending a command for one direction, doesn't change the opposite direction mode.

RC-panel buttons and indicators are shown in Fig. 10.

- After sending "Single passage in a set direction" command speed gate intrusion detectors control the presence of a user in the passageway. After completing the passage, the speed gate switches to the "Always locked" mode.
- After sending "Single passage in a set direction" command, if the passage was not performed or another command was not sent, speed gate swing panels get closed automatically after **Holding in unlocked state** (8 seconds by default) expiration, the speed gate switches to the "Always locked" mode.
- After sending "Single passage in a set direction" command, if the passage was not performed, the command can be resent and **Holding in unlocked state** countdown starts again.
- After sending "Single passage in a set direction" command, the "Free passage" command for the other direction will be ignored.

- After sending “Free passage in a set direction” command, only “Always locked” or “Single passage in a set direction” command for the opposite direction can be sent, all other commands will be ignored.

Table 7. Pulse control mode

Command	RC-panel operator actions ¹	Indication		Speed gate state
		RC-panel	Central post	
“Always locked”	Press the STOP button	Red “Stop” indicator is on	Red for both directions	The swing panels are closed
“Single passage in a set direction”	Press the LEFT/ RIGHT buttons	Red “Stop” indicator is on and the green indicator for the set direction “Left”/ “Right” is on	Green for the set direction	The swing panels turn in the passage direction
“Free passage in a set direction”	Press both STOP and LEFT/ RIGHT buttons simultaneously.	Green indicator of the set direction “Left”/ “Right” is on	Green for the set direction	The swing panels are open in the free passage direction until receiving the next command
“Free passage”	Press all three LEFT, STOP and RIGHT buttons simultaneously	Both green indicators “Left” and “Right” are on	Green for both directions	Swing panels are open until receiving the next command

9.3 Potential control mode

Speed gate control command sending and its indication are performed according to Table 8. Passage directions are independent of each other, i.e. sending a command for one direction does not change the opposite passage direction mode.

Table 8. Potential control mode

Command	Required to ensure	Indication		Speed gate state
		RC-panel	Central post	
“Both directions closed”	High level on <i>Unlock A</i> and <i>Unlock B</i> contacts (or low level on <i>Stop</i> contact)	Red “Stop” indicator is on	Red for both directions	Swing panels are closed
“Direction open”	Low level on the contact of the chosen direction. High level on all other contacts	Green indicator of the chosen “Left”/ “Right” direction is on	Green for the chosen direction	Swing panels turn in the passage direction
“Both directions open”	Low level on <i>Unlock A</i> and <i>Unlock B</i> contacts. High level on <i>Stop</i> contact	Both green “Left” and “Right” indicators are on	Green for both directions	Swing panels are open until receiving the new command

9.4 In case of an emergency

9.4.1 “Emergency” mode

In case something interferes with the free rotation of the swing panels, the speed gate automatically switches into “Emergency” mode. This mode is required to avoid motor drive failure, caused by overheating.

If there is an obstacle, interfering with the swing gate rotation in the set direction, three turns in the same direction with a 3 seconds interval are performed. If the obstacle is not removed, the speed

¹ Speed gate control from the WRC is the same as the control from the RC-panel. Buttons on the WRC for control the same functions as the RC-panel buttons.

gate switches to the “*Emergency*” mode. In “*Emergency*” mode speed gate swing panels can turn freely at a $\pm 90^\circ$ angle, which allows removing the obstacle from the passage lane with ease. In this case all three light indicators of the RC-panel are on and sound indication of 3 short sound signals, with a period of 20 seconds each is on.

“*Emergency*” mode is switched off automatically after the obstacle is removed, the speed gate passage lane is freed and the swing panels are set into an initial (closed) position.

The “*Alarm*” signal is automatically generated if the passage lane of the speed gate is occupied by something or someone for more than 30 seconds. The signal will be deactivated after the passage lane is cleared.

9.4.2 “Fire Alarm” mode

In case of hazardous situations on the territory of the facility, the speed gate zone can be used as an additional emergency exit.

It is possible to place the speed gate into the “*Fire Alarm*” mode from the emergency opening device (Fire alarm device, emergency button, etc.). In this mode, the swing panels open in one of the directions and remain open for free passage in both directions; simultaneously, for both directions, green indicators of the pass enable in the flashing mode are switched on in the indication block. Other commands at this mode are ignored (Sect. 5.3.2).

Also, as a power loss, the swing panels can be opened manually (they are not blocked).

9.4.3 Troubleshooting

Possible faults to be corrected by the customers themselves are listed in Table 9.

For faults not listed in Table 9 we advise to consult with **PERCo** Technical Support Department.

Table 9. Troubleshooting and remedy

Fault	Most probable cause	Remedy
Power supplies are on, but the speed gate does not function, the RC-panel lights and the LED indicators are off.	Faulty connection or breakdown in the speed gate power supply cable.	Disconnect the speed gate power supply from the mains, open the central post cover plate. Check the integrity of the power cable, check the reliability of the power cords in the XT3 terminal block of the control board.
One of the indication blocks does not work, while the speed gate operation corresponds to the algorithm	No control signal is sent to the indication block	Check the integrity of the connecting cable of the indication block, check the reliability of its connection in the connectors.

10 MAINTENANCE

Technical maintenance is to be performed by qualified specialists after careful study of this Manual.

Use liquid nonabrasive cleaners, containing aqua ammonia to remove the contaminations of the speed gate sections and swing panels.

11 TRANSPORTATION AND STORAGE

Speed gate storage is allowed in dry indoor facilities at an ambient air temperature from -40°C to $+50^\circ\text{C}$ at relative air humidity 80% at $+15^\circ\text{C}$.

Speed gate in the original package should be transported in closed freight containers or others closed type cargo transport units.

Do not stack the boxes with the speed gates during transportation and storage.

After transportation or storage at temperatures below zero or at high air humidity, prior to installation the speed gate must be kept in the original package for no less than 24 hours indoors at room temperatures.

Appendix 1. Operation algorithm at pulse control mode

“Always locked” (locked for entry and exit) – active front at the *Stop* contact while there is a high level at the *Unlock A* and *Unlock B* contacts. Both passage directions are locked at this command.

“Single passage in A direction” (open for passage of one person in A direction) – active front at *“Unlock A”* contact, while there is a high level at *“Stop”* and *“Unlock B”* contact. At this command the passage direction A opens either for 5 sec. or until the passage has been made in this direction or until the command *“Always locked”*, and the status of the passage direction B does not change at that. The command is ignored if at the moment of its receipt the status of the passage direction A is *“Always free”*.

“Single passage in B direction” (open for passage of one person in B direction) – active front at the contact *“Unlock B”* while there is a high level at the contacts *“Stop”* and *“Unlock A”*. At this command the passage direction B opens either for 5 sec. or until the passage has been effected in this direction or until the command *“Always locked”*, and the status of the passage direction A does not change. The command is ignored if at the moment of its receipt the status of passage direction B is *“Free passage”*.

“Free passage in A direction” (open for free passage in A direction) – active front at the contact *“Unlock A”* while there is a low level at the contact *“Stop”* and a high level at the contact *“Unlock B”*, or active front is at the contact *“Stop”* while there is a low level at the contact *“Unlock A”* and a high level at the contact *“Unlock B”*. At this command the passage direction A opens until the command *“Always locked”* is received; the status of the passage direction B does not change at that.

“Free passage in B direction” (open for free passage in B direction) – Active front is at the contact *“Unlock B”* while there is a low level at the contact *“Stop”* and a high level at the contact *“Unlock A”*, or active front is at the contact *“Stop”* while there is a low level at the contact *“Unlock B”* and a high level at contact *“Unlock A”*. At this command the passage direction B opens until the command *“Always locked”* is received; the status of the passage direction A does not change at that.

“Free passage” (open for free passage in both directions) – Active front is at the contact *“Unlock A”* while there is a low level at the contacts *“Unlock B”* and *“Stop”*, or active front is at the contact *“Unlock B”* while there is a low level at the contacts *“Unlock A”* and *“Stop”*, or active front is at the contact *“Stop”* while there is a low level at the contacts *“Unlock A”* and *“Unlock B”*. Both directions open at this command until the command *“Always locked”* is received.

Appendix 2. Operation algorithm at potential control mode

“Both directions are locked” (locked for entry and exit). There is a high level at the *“Unlock A”* and *“Unlock B”* contacts or a low level at the *“Stop”* contact. Both passage directions are locked at this command.

“A direction is open” (open for passage in A direction). There is a low level at the *“Unlock A”* contact while a high level is present at the *“Stop”* and *“Unlock B”* contacts. At this command the direction A opens till the low-level signal removed from the contact A or until the *“Both directions locked”* command is received. The status of the direction B does not change at that.

“B direction is open” (open for passage in B direction). There is a low level at the *“Unlock B”* contact while there is a high level at the *“Stop”* and *“Unlock A”* contacts. At this command the direction B opens till the low-level signal removed from the contact B or until the *“Both directions locked”* command is received. The status of the direction A does not change at that.

“Both directions are open” (open for entry and exit in both directions). There is a low level at the *“Unlock A”* and *“Unlock B”* contacts while there is a high level at the *“Stop”* contact. Both directions open at this command till the low-level signal removed from one of the contacts A (B) or until the *“Both directions locked”* command is received.

PERCo

Polytechnicheskaya str., 4, block 2
194021, Saint Petersburg
Russia

Tel: +7 812 247 04 64

**E-mail: export@perco.com
support@perco.com**

www.perco.com



www.perco.com